

SEALING LOCKING NUTS

METAL EXPANSION PLUGS

MINI CHECK VALVES



The solution
for
Sealing and fluid control
ISO/TS16949 – ISO9001



*Sealing and Fluid Control Technology
Solutions for process port sealing and fluid control*

TECNIMETAL

Via degli Andreani, 9 - 40037 Sasso Marconi (BO) - ITALY
Tel: +39 051 735744
E-mail: info@tecnimetal-tm.com
www.tecnimetal-tm.com

SEALING LOCKING NUTS



ISO/TS16949 – ISO9001

Sealing and Fluid Control Technology

SPECIFICATIONS:

- Flanged Nuts class 8 (28-32Hrc)
- Surface treatment: Galvanized or Phosphated
- Seal Ring Nylon PA11 Oil Resistant
- Temperatures -40°C / +120°C
- Seal Ring Injection Molding installed
- Single body seal ring and nut
- Seal ring with thread shape
- Can be reused 5 times and above
- Sealing pressure 25Mpa and above

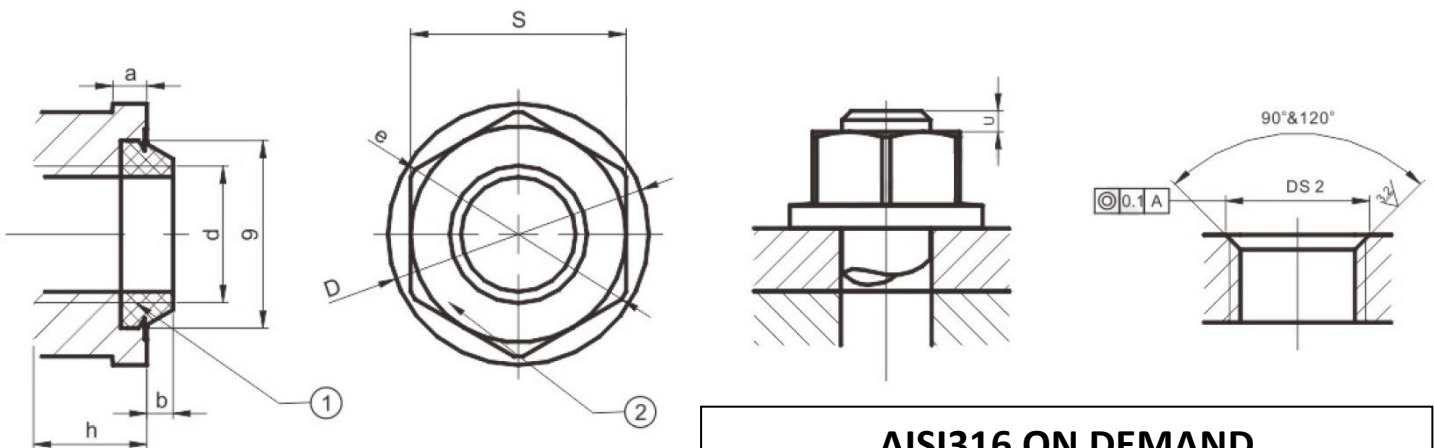

AISI316 ON DEMAND
Marine, Medical, Food

OTHER SIZES ON DEMAND

Code Galvanized	Code Phosphated	Code AISI 316	Threads M	D mm	S mm	H mm	Tightening Nm
-	-	SLN-M5X0.8-316	M5x0.8	11	9	7	5 - 6
SLN-M6X0.5	SLN-M6X0.5-PH	SLN-M6X0.5-316	M6x0.5	12	10	7	10.1 - 11.1
SLN-M6X1	SLN-M6X1-PH	SLN-M6X1-316	M6x1	12	10	7	9.0 - 10.1
SLN-M8X1	SLN-M8X1-PH	SLN-M8X1-316	M8x1	17	13	8.5	22.8 - 26.5
SLN-M8X1.25	SLN-M8X1.25-PH	SLN-M8X1.25-316	M8x1.25	17	13	8.5	21.6 - 24.6
SLN-M10X1	SLN-M10X1-PH	SLN-M10X1-316	M10x1	21	17	9	46 - 53
SLN-M10X1.5	SLN-M10X1.5-PH	SLN-M10X1.5-316	M10x1.5	21	17	9	46 - 48
SLN-M12X1	SLN-M12X1-PH	SLN-M12X1-316	M12x1	23	19	10	82 - 94
SLN-M12X1.25	SLN-M12X1.25-PH	SLN-M12X1.25-316	M12x1.25	23	19	10	78 - 91
SLN-M12X1.5	SLN-M12X1.5-PH	SLN-M12X1.5-316	M12x1.5	23	19	10	78 - 90
SLN-M12X1.75	SLN-M12X1.75-PH	SLN-M12X1.75-316	M12x1.75	23	19	10	73 - 84
SLN-M14X1.5	SLN-M14X1.5-PH	SLN-M14X1.5-316	M14x1.5	27	22	11	124 - 142
SLN-M16X1.5	SLN-M16X1.5-PH	SLN-M16X1.5-316	M16x1.5	37	30	18	189 - 218
SLN-M16X2	SLN-M16X2-PH	SLN-M16X2-316	M16x2	37	30	18	180 - 206

Sizes, images and technical data are purely indicative, we reserve the right to make changes at any time without notice

METAL EXPANSION PLUGS



Sealing and Fluid Control Technology dei fluidi



FEATURES EXPANSION PLUGS SERIES HC EXP

Maximum working pressure over 450BAR/6500PSI

Metric sizes from 3 to 22mm, in inches or special on request.

Corrosion resistant

Passivated 400 series stainless steel body

Ball in bearing steel or 400 series stainless steel

Available with aluminum body on request

Available in AISI 316 or other materials

Model E (Easy Install) on request, with low installation pressure for max 450BAR/6500PSI working pressure, ideal for applications where the normal installation pressure of the sphere could cause undesired deformations to the part.

Tested: Each batch is tested to exceed maximum static pressure prior to explosion or extrusion.

Certificates of dimensional conformity, seal tests and materials available on request.

Work tests can be done on specific customer requests with cycles of different pressures and temperatures to simulate the specific working conditions of the customer's application.

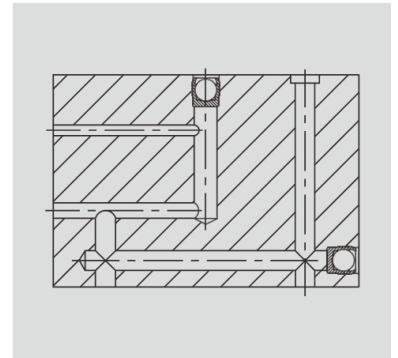
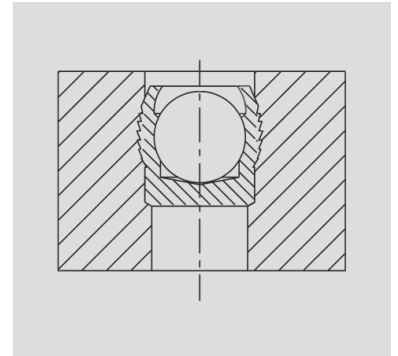

HOLE PREPARATION

Refer to the data in the catalog to determine the diameter and tolerances of the plug seat (D2), of the hole to be sealed (D1) and of the D2/D3 ratio

- The roundness of the hole must be within 0.05mm
- Hole roughness should be between Rz10-30m μ (Ra3.2-6.4) especially for hard materials
- Spiral or longitudinal scratches should be avoided as they can affect the performance of the plug
- Make sure the plug seat is clean and free from cutting oils, chips, etc

INSTALLATION PROCEDURE

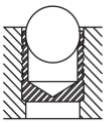
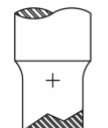

FIG. 1

Insert the plug into the seat with the ball facing outwards and in contact with the internal shoulder. It is of fundamental importance that the diameter of the seat and of the hole to be plugged are of the correct dimensions so the plug is properly supported during installation and there is a good seal



Press the ball into the sleeve so that the top of the ball is slightly below the top level of the sleeve (See Figs. 2 and 3). Approximate S and X stroke values are listed in the table below.

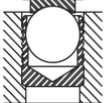

FIG. 2

Make sure you have the correct installation tool for each cap size
EXP-41, EXP-44, EXP-88, EXP-54 plugs can be installed using a hammer and the appropriate manual installation tool. A punch or air hammer with the appropriate installation tool can also be used.



FIG. 3

EXP-41, EXP-44, EXP-88, EXP54 plugs can also be installed in an automated way.

SERIES HC EXP METRIC



EXP-41 series

“4” Cap – Passivated 400 Stainless Steel
 “1” Ball – Black oxidized bearing steel



EXP-44 series

“4” Cap – Passivated 400 Stainless Steel
 “4” Ball – Passivated 400 Stainless Steel



EXP-54 series

“5” Cap – Anodized Aluminum
 “4” Ball – Passivated 400 Stainless Steel



EXP-88 series

“8” Cap - AISI316 Stainless Steel
 “8” Sphere – AISI316 Stainless Steel

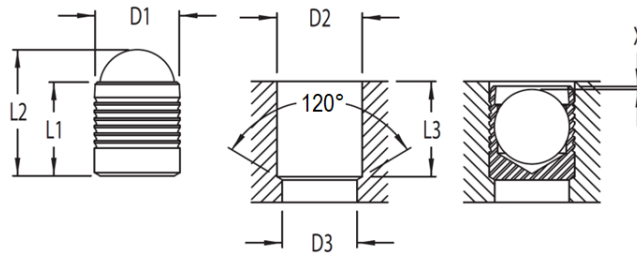

*OTHER MATERIALS
AND SIZES ON
DEMAND*

HC EXP Metric

D1 mm	L1 mm	L2 mm	D2 +0.1/-0 mm	D3 max mm	L3 min mm	X mm	COD EXP-41	COD EXP-44	COD EXP-88	COD EXP-54
3	3.6	4.7	3	2.2	3.4	0.4	EXP-41-030	EXP-44-030	EXP-88-030	EXP-54-030
4	4.0	5.1	4	3.3	4.1	0.4	EXP-41-040	EXP-44-040	EXP-88-040	EXP-54-040
5	5.5	7.1	5	4.3	5.3	0.4	EXP-41-050	EXP-44-050	EXP-88-050	EXP-54-050
6	6.5	8.6	6	5.3	6.4	0.4	EXP-41-060	EXP-44-060	EXP-88-060	EXP-54-060
7	7.5	10.1	7	6.4	7.4	0.4	EXP-41-070	EXP-44-070	EXP-88-070	EXP-54-070
8	8.5	11.6	8	7.4	8.3	0.4	EXP-41-080	EXP-44-080	EXP-88-080	EXP-54-080
9	10.0	13.5	9	8.4	9.8	0.4	EXP-41-090	EXP-44-090	EXP-88-090	EXP-54-090
10	11.0	15.1	10	9.4	10.8	0.4	EXP-41-100	EXP-44-100	EXP-88-100	EXP-54-100
12	13.0	17.8	12	10.6	12.8	0.4	EXP-41-120	EXP-44-120	EXP-88-120	-
14	15.0	20.4	14	12.7	14.5	0.4	EXP-41-140	EXP-44-140	EXP-88-140	-
16	17.0	23.4	16	14.7	16.5	0.6	EXP-41-160	EXP-44-160	EXP-88-160	-
18	19.0	26.3	18	16.7	18.5	0.6	EXP-41-180	EXP-44-180	EXP-88-180	-
20	22.0	30.0	20	18.7	21.5	0.6	EXP-41-200	EXP-44-200	EXP-88-200	-
22	25.0	34.0	22	20.7	24.5	0.6	EXP-41-220	EXP-44-220	EXP-88-220	-

on request EXP-xxx-xxx **E** Easy install (max450bar), less effort required for installation, ideal for applications where the normal installation pressure of the ball could cause unwanted deformations.

HC EXP Nominal Working Pressure – Hole Preparation					
diameters mm	A356	2024-T4	EN-GJS-500	GJS-600	ETG-100
Ø3-10 (41-44-88)	380 BAR			450 BAR	
Ø12-16 (41-44-88)	280BAR			350 BAR	
Ø3-10 (54)	180BAR				
Hole preparation					
Tolerance	0/+0.1mm				
Finish	Rz10-30 / Ra 3.2-6.4				



HC EXP SERIES INCH



EXP-41 series

"4" Cap – Passivated 400 Stainless Steel
 "1" Ball – Black oxidized bearing steel

EXP-44 series

"4" Cap – Passivated 400 Stainless Steel
 "4" Ball – Passivated 400 Stainless Steel

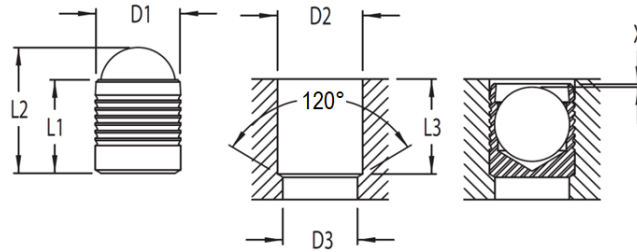

OTHER MATERIALS
 AND SIZES ON
 DEMAND

HC EXP Inches

D1 inches	L1 inches	L2 inches	D2 +0.004"/-0 inches	D3 max inches	L3 min inches	X inches	COD EXP-41	COD EXP-44
0.156	0.158	0.21	0.1562	0.130	0.149	0.008	EXP-41-0156	EXP-44-0156
0.187	0.217	0.27	0.1875	0.160	0.208	0.010	EXP-41-0187	EXP-44-0187
0.218	0.217	0.28	0.2187	0.190	0.208	0.010	EXP-41-0218	EXP-44-0218
0.250	0.256	0.34	0.2500	0.220	0.247	0.010	EXP-41-0250	EXP-44-0250
0.281	0.296	0.40	0.2812	0.250	0.287	0.010	EXP-41-0281	EXP-44-0281
0.312	0.335	0.46	0.3125	0.281	0.326	0.010	EXP-41-0312	EXP-44-0312
0.343	0.394	0.52	0.3437	0.312	0.385	0.010	EXP-41-0343	EXP-44-0343
0.375	0.394	0.54	0.3750	0.343	0.385	0.010	EXP-41-0375	EXP-44-0375
0.406	0.434	0.59	0.4062	0.375	0.425	0.010	EXP-41-0406	EXP-44-0406
0.437	0.512	0.68	0.4375	0.406	0.503	0.010	EXP-41-0437	EXP-44-0437
0.468	0.512	0.71	0.4687	0.437	0.503	0.010	EXP-41-0468	EXP-44-0468
0.562	0.591	0.82	0.5625	0.510	0.570	0.010	EXP-41-0562	EXP-44-0562
0.625	0.669	0.91	0.6250	0.562	0.649	0.010	EXP-41-0625	EXP-44-0625
0.687	0.748	1.03	0.6875	0.625	0.727	0.010	EXP-41-0987	EXP-44-0987
0.750	0.866	1.18	0.7500	0.688	0.845	0.010	EXP-41-0750	EXP-44-0750
0.875	0.984	1.35	0.8750	0.813	0.963	0.010	EXP-41-0875	EXP-44-0875

on request EXP-xxx-xxx _E Easy install (max450bar), less effort required for installation, ideal for applications where the normal installation pressure of the ball could cause unwanted deformations.

HC EXP Nominal Working Pressure – Hole Preparation

diameters mm	A356	2024-T4	EN-GJS-500	GJS-600	ETG-100
Ø0.156-0.375	380 BAR		450 BAR		
Ø0.406-0.875	280BAR		350 BAR		
Hole preparation					
Tolerance	0/+0.004"				
Finish	Rz10-30 / Ra 3.2-6.4				



Installation by pneumatic hammer

powerful, simple to use, ergonomic,
low maintenance costs, compact

REDUCED VIBRATIONS = SAFETY FOR OPERATORS

MANNESMANN DEMAG



MD 070-072-080



MD 120



MD 084

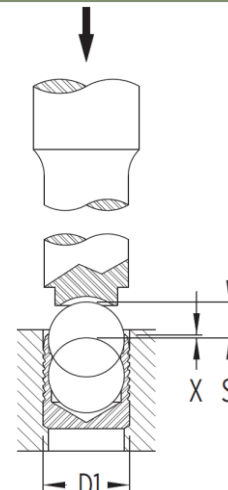

Technical features

Insert Round R10.3x36	Model Code	MD 070 60040065	MD 072 60054685	MD 080 60040105	MD 110 60040085	MD 120 60040125	MD 084 60040525
Handle		Pistol	Pistol	Pistol	Handle	Handle	Axial
Chisel retention		●	●	●	●	●	●
Beats per min		6,500	3,400	6,500	6,500	4,400	4,400
Impact power	j	1.1	1.1	1.2	1.1	3.5	-
Air consumption	l/sec	3.3	3.3	5.6	6.6	5.3	0.3
Ø Piston	mm	16	16	16	16	16	16
Piston stroke	mm	30	46	45	30	45	45
Length	mm	170	175	190	205	229	193
Weight	Kg	0.7	0.7	0.8	1.0	1.1	0.86
Inner Tube Ø	mm	8	8	8	8	8	8
Attack		G1/4"	G1/4"	G1/4"	G1/4"	G1/4"	G1/4"
Vibrations	m/s²	3.0	4.2	3.3	2.5	4.2	3.3
Exposition time	h	21.9	11.1	18.4	32.1	11.1	2.4
Noisiness	dB(A)	98	98	98	98	98	95

Data referred to an operating pressure of 6Bar - www.mannesmann-demag.com

AH series

Tools for pneumatic hammer or manual use

D1 mm	D3 inches	L1 mm	D2 mm	X +/-0.2 mm	COD.
3.0	.401	100	2.8	0.4	EXP-AH-030
4.0	.401	100	3.8	0.2	EXP-AH-040
5.0	.401	100	4.7	0.4	EXP-AH-050
6.0	.401	100	5.8	0.4	EXP-AH-060
7.0	.401	100	6.8	0.4	EXP-AH-070
8.0	.401	100	7.8	0.3	EXP-AH-080
9.0	.401	100	8.7	0.4	EXP-AH-090
10.0	.401	100	9.8	0.4	EXP-AH-100
12.0	.401	100	11.7	0.4	EXP-AH-120
14.0	.401	100	13.7	0.4	EXP-AH-140
16.0	.401	100	15.7	0.6	EXP-AH-160
18.0	.401	100	17.7	0.6	EXP-AH-180
20.0	.401	100	19.7	0.8	EXP-AH-200
22.0	.401	100	21.7	0.8	EXP-AH-220

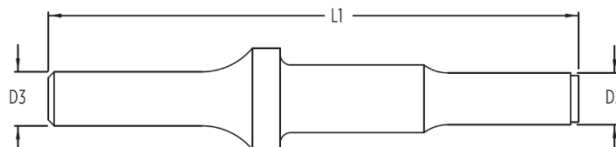

DESIGN

MINIMUM WALL THICKNESS AND DISTANCE FROM EDGES

Radial expansion of the plugs causes plastic deformation in the material around the plug housing. It is necessary that a wall thickness and an edge distance be maintained so as to optimize the strength of the mechanical connection between the plug and the housing. The operating hydraulic pressure, the thermal cycle, the type of plug and the characteristics of the support material are all parameters to be considered for the determination of the minimum distance values and wall thickness.

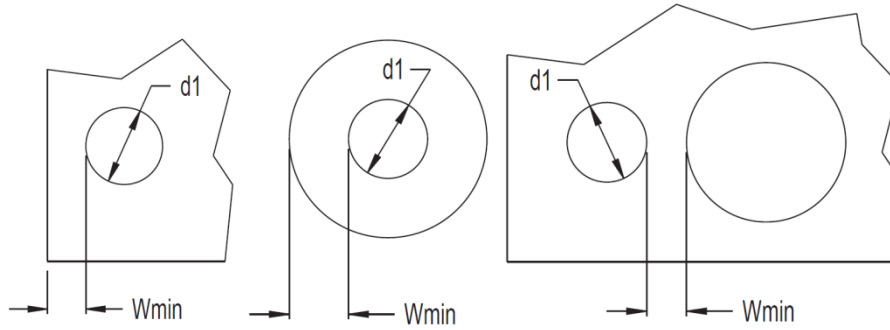

Guidelines for determining the minimum wall thickness and minimum edge distance (W_{min}) are given below. These minimum values to be respected mean that only a slight deformation of the external profile of a value of less than $20\ \mu m$ is produced. This does not affect the performance of the plugs. If the minimum recommended W_{min} values are not respected, the support material can be overloaded, affecting the performance of the closures.

Cap diameter: $d1 \geq 4mm$: $W_{min} = f_{min} * d1$
 $d1 < 4mm$: $W_{min} = f_{min} * d1 + 0.5mm$

Plug Sseries	Support material						
	SAE 1144	SAE 10L15	ASTM A48 Cast iron	ASTM A356 Cast iron	2024-T4	6061-T4	356-T6 Aluminum
	Factor f_{min}						
EXP-41_E	0.5	0.6	1.0	0.6	0.6	1.0	1.0
EXP-41/44/88	0.6	0.8	1.0	0.8	0.8	1.0	1.0



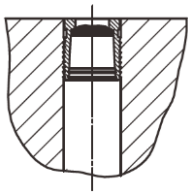

EXP-RS Metric series

Plug - Case-hardened steel, black oxidation finish
Shank – Tempered Steel, Black Oxidation Finish

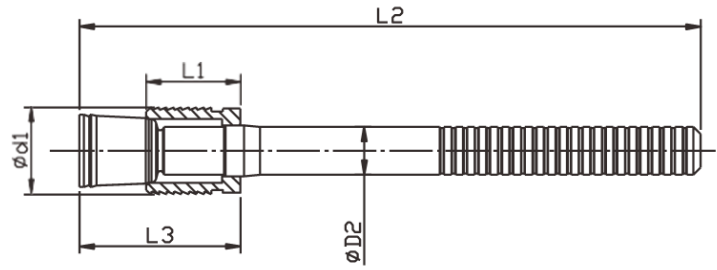
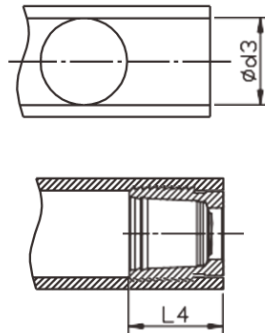
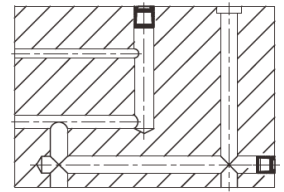

D1 mm	L1 mm	D2 mm	L2 mm	L3 max mm	L4 max mm	D3 +0.12/-0.0 mm	COD
4.0	4.0	2.50	39	9.0	6.5	4.0	EXP-RS-040
5.0	5.5	3.00	41	10.0	7.5	5.0	EXP-RS-050
6.0	6.5	3.40	43	12.0	8.0	6.0	EXP-RS-060
7.0	7.5	4.10	38	14.0	9.0	7.0	EXP-RS-070
8.0	8.5	4.20	40	15.0	10.5	8.0	EXP-RS-080
9.0	9.5	4.50	43	17.0	11.0	9.0	EXP-RS-090
10.0	10.5	4.75	45	19.0	12.5	10.0	EXP-RS-100

HC EXP RS Nominal Working Pressure – Hole Preparation

diameters mm	A356	2024-T4	EN-GJS-500	GJS-600	ETG-100
Ø4-10	380 BAR			500 BAR	
Hole preparation					
Tolerance	0/+0.12mm				
Finish	Rz10-30 / Ra 3.2-6.4				



EXP-RSL Series Metric

Plug - Case-hardened steel, black oxidation finish
Shank – Tempered Steel, Black Oxidation Finish

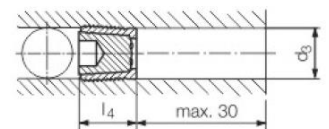
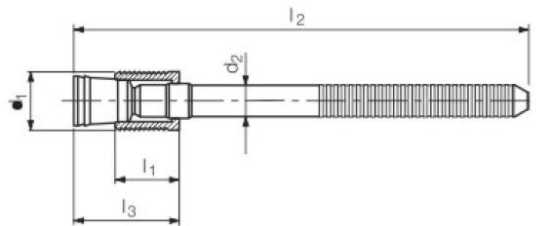
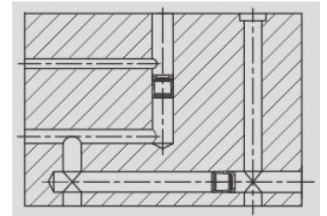

D1 mm	L1 mm	D2 mm	L2 mm	L3 max mm	L4 max mm	D3 +0.12/-0.0 mm	COD
4.0	4.0	2.50	69	9.0	6.5	4.0	EXP-RSL-040
5.0	5.5	3.00	71	10.0	7.5	5.0	EXP-RSL-050
6.0	6.5	3.40	73	12.0	8.0	6.0	EXP-RSL-060
7.0	7.5	4.10	68	14.0	9.0	7.0	EXP-RSL-070
8.0	8.5	4.20	70	15.0	10.5	8.0	EXP-RSL-080
9.0	9.5	4.50	73	17.0	11.0	9.0	EXP-RSL-090
10.0	10.5	4.80	75	19.0	12.5	10.0	EXP-RSL-100

HC EXP RSL Nominal Working Pressure – Hole Preparation

diameters mm	ETG-100 44SMn28 AISI1144	C14Pb 1.0403	EN-GJL-250 EN1561	EN-GJS-500-7 EN1563	AlCu4Mg1 ENAW-2024-T3	AlMgSiPb ENAW-6012-T6	G-AISI7Mg ENAC-42100/A356
Ø4-10	500BAR / 7200PSI					450BAR/6500PSI	

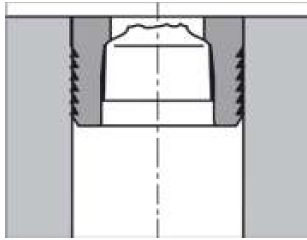

EXP-RL Metric series

Plug - Steel
Stem - Steel

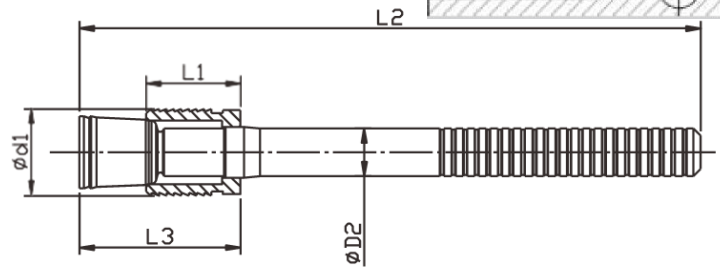
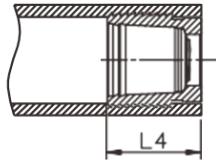
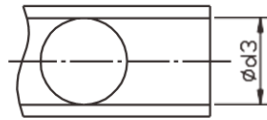
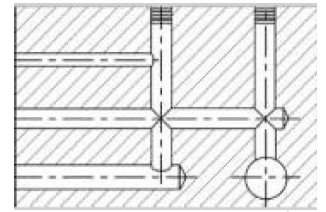

D1 mm	L1 mm	D2 mm	L2 mm	L3 max mm	L4 max mm	D3 Toll* mm	COD
4.0	3.7	2.2	36	5.0-5.5	4.0	4.0	EXP-RL-040
5.0	4.5	3.0	36	6.4-6.9	4.8	5.0	EXP-RL-050
6.0	5.0	3.4	36	7.2-7.7	5.3	6.0	EXP-RL-060
7.0	5.5	4.2	34	7.9-8.5	5.8	7.0	EXP-RL-070
8.0	6.5	4.3	34	9.2-9.8	6.8	8.0	EXP-RL-080
9.0	6.5	4.7	34	9.2-9.8	6.8	9.0	EXP-RL-090
10.0	6.5	5.1	36	9.2-9.8	6.8	10.0	EXP-RL-100
12.0	7.5	5.9	36	11.0-11.7	7.8	12.0	EXP-RL-120
14.0	8.0	5.9	36	11.5-12.2	9.0	14.0	EXP-RL-140
16.0	10.5	5.9	42	15.5-16.5	11.5	16.0	EXP-RL-160
18.0	11.0	6.5	50	16.7-17.7	13.0	18.0	EXP-RL-180

Toll*: Materials <280HB Housing tolerance 0/+0.12mm
Materials >280HB Housing tolerance +0.05/+0.15mm

HC EXP RL Nominal Working Pressure – Hole Preparation

diameters mm	ETG-100 44SMn28 AISI1144	C14Pb 1.0403	EN-GJL-250 EN1561	EN-GJS-500-7 EN1563	AlCu4Mg1 ENAW-2024-T3	AlMgSiPb ENAW-6012-T6	G-AlSi7Mg ENAC-42100/A356
Ø4-18	60BAR / 850PSI						



EXP-RLC Metric series

Plug – Stainless Steel
Stem – Stainless Steel

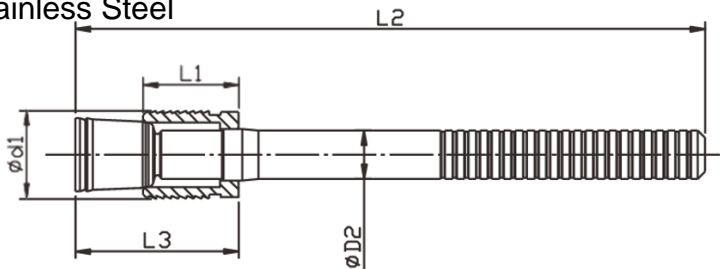
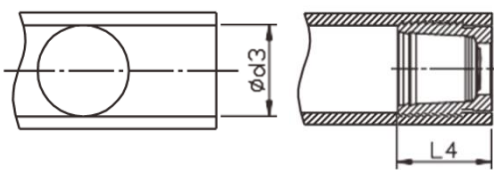

D1 mm	L1 mm	D2 mm	L2 mm	L3 max mm	L4 max mm	D3 Toll* mm	COD
4.0	3.7	2.2	36	5.0-5.5	4.0	4.0	EXP-RLC-040
5.0	4.5	3.0	36	6.4-6.9	4.8	5.0	EXP-RLC-050
6.0	5.0	3.4	36	7.2-7.7	5.3	6.0	EXP-RLC-060
7.0	5.5	4.2	34	7.9-8.5	5.8	7.0	EXP-RLC-070
8.0	6.5	4.3	34	9.2-9.8	6.8	8.0	EXP-RLC-080
10.0	6.5	5.1	36	9.2-9.8	6.8	10.0	EXP-RLC-100

Toll*: Materials <280HB Housing tolerance 0/+0.12mm
Materials >280HB Housing tolerance +0.05/+0.15mm

HC EXP RL Nominal Working Pressure – Hole Preparation

diameters mm	ETG-100 44SMn28 AISI1144	C14Pb 1.0403	EN-GJL-250 EN1561	EN-GJS-500-7 EN1563	AlCu4Mg1 ENAW-2024-T3	AlMgSiPb ENAW-6012-T6	G-AlSi7Mg ENAC-42100/A356
Ø4-10	60BAR / 850PSI						

HOLE PREPARATION

Refer to the data in the catalog to determine the diameter and tolerances of the Plug seat (D3).

- The roundness of the hole must be within 0.05mm
- The roughness of the hole must be between Rz 10-30 μm – Ra3.2-6.4 especially for hard materials
- Spiral or longitudinal scratches should be avoided as they can affect the performance of the Plug
- Make sure the plug seat is clean and free from cutting oils, chips, etc

INSTALLATION PROCEDURE

- The work area must be clean
- RS Plug are ready to use as shipped, do not clean or lubricate the Plug or stem
- Insert the shank into the tool, make sure the Plug is against the nose of the tool (FIG.1)
- Insert the plug into the hole, make sure the nose of the tool is pressed against the part and perpendicular (FIG.2)
- Activate the tool to expand the cap, the stem will break when the Plug expansion is achieved (FIG.3)
- Make sure you purchase the correct tool for each Plug size you are installing

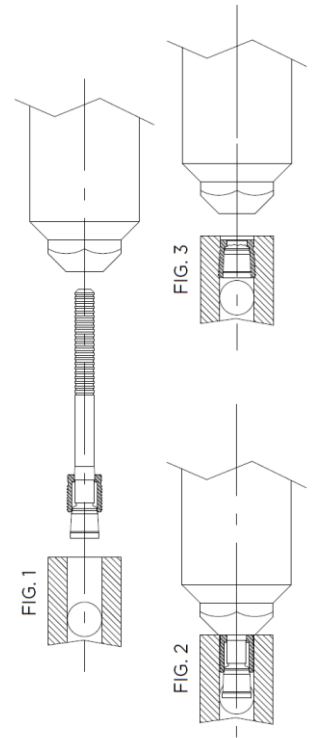

REMOVAL PROCEDURE

- Using a punch, push the piece of stem out of the Plug
- Remove the Plug with a point and remove the piece of stem from the hole
- Make sure that you have removed chips, pieces of oil plug and any foreign bodies from the hole
- Install a new RS cap



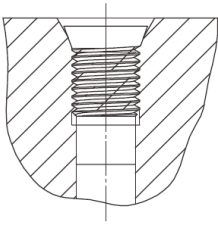

CLW - CLP Screw plugs

Versatile and usable in multiple applications

Tightness up to 450BAR/6500PSI

The use of sealant is recommended

Fillets 100% controlled

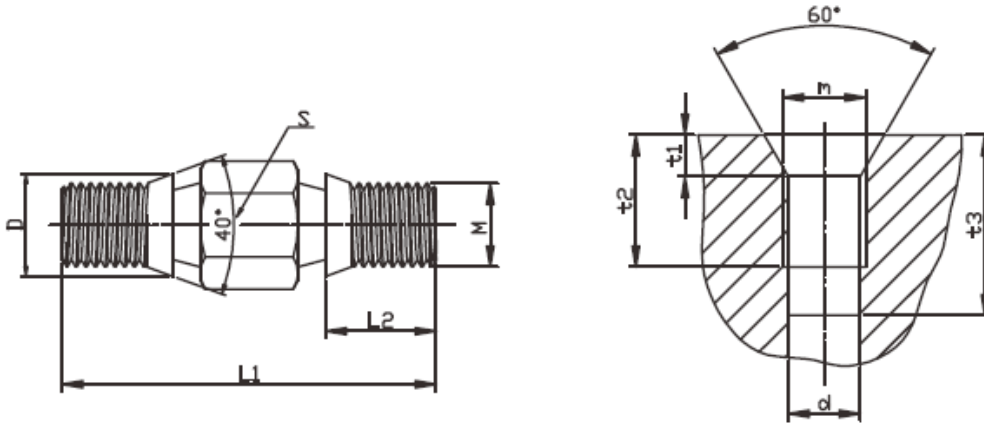
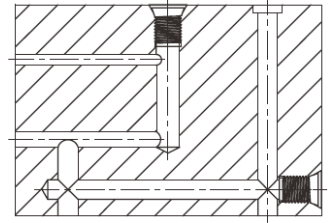

CLW extension

Low Carbon Steel - Surface Oxidation Treatment

COD.	M	L1 +/-0.5	L2 +/-0.2	D +/-0.2	S	M	t1	t2 +0.1/-0	D 0/-1	t3 +1
CLW4	4	22	7	5.4	7	4	3	9.5	3.3	13
CLW5	5	22	7	6.4	7	5	3	9.5	4.2	13
CLW6	6	24	8	7.4	8	6	3	10.5	5.0	15.5
CLW8	8	25	8	9.4	10	8	4	11.5	6.8	15.5
CLW10	10	33	10	11.4	14	10	4	12.5	8.5	17.5
CLW12	12	33	10	13.4	17	12	4	12.5	10.2	17.5

CLP extension

Hardened steel - Surface oxidation treatment

COD.	M	L1 +/-0.5	L2 +/-0.2	D +/-0.2	S	M	t1 +0.5	t2 +0.1/-0	D 0/-1	t3 +1
CLP4	4	25	7	5.4	7	4	3	9.5	3.3	13
CLW5	5	29	7	6.4	7	5	3	9.5	4.2	13
CLW6	6	31	8	7.2	8	6	3	10.5	5.0	15.5
CLW8	8	31	8	9.4	10	8	4	11.5	6.8	15.5
CLW10	10	35	10	11.4	14	10	4	12.5	8.5	17.5
CLW12	12	36	10	13.4	19	12	4	12.5	10.2	17.5

HC CLW Nominal Working Pressure

diameters mm	A356	2024-T4	EN-GJS-500	GJS-600	ETG-100
M4-8	450 BAR				
M10-12					

Hole preparation: if in doubt, contact our technical office

FC[®] "Clw" Plug



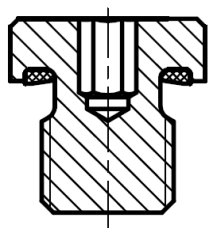

Sealed threaded plugs
320BAR/4300PSI
ED pad gasket
Tempered steel
Surface oxidation treatment

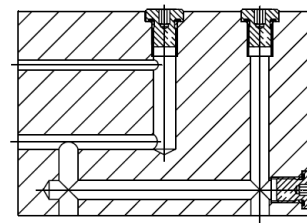

GAS

COD.	E thread	ED Seal Ring	A	L	S	D	Nm
HCEG02	G1/8"X28	ED-10	8	12	5	14	11-13
HCEG04	G1/4"X19	ED-14	12	17	6	19	25-30
HCEG06	G3/8"X19	ED-17	12	17	8	22	42-58
HCEG08	G1/2"X14	ED-21	14	19	10	27	72-82
HCEG12	G3/4"X14	ED-27	16	21	12	32	120-140
HCEG16	G1"X11	ED-33	16	22	17	40	150-180
HCEG20	G1.1/4"X11	ED-42	16	22	22	50	190-280
HCEG24	G1.1/2"X11	ED-48	16	22	24	55	260-350
HCEG32	G2"X11	ED-60	18	26	27	70	340-400
HCEG40	G2-1/2"X11	ED-B40			27		340-400

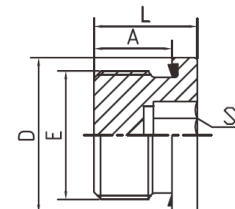

METRIC

COD.	E thread	ED Seal Ring	A	L	S	D	Nm
HCEM08	M8X1	ED-8	8	12	4	12	8-10
HCEM10	M10X1	ED-10	8	12	5	14	10-12
HCEM12	M12X1.5	ED-12	12	17	6	17	15-25
HCEM14	M14X1.5	ED-14	12	17	6	19	20-35
HCEM16	M16X1.5	ED-16	12	17	8	22	25-40
HCEM18	M18X1.5	ED-18	12	17	8	24	30-45
HCEM20	M20X1.5	ED-20	14	19	10	26	35-50
HCEM22	M22X1.5	ED-22	14	19	10	27	40-70
HCEM24	M24X1.5	ED-24	14	19	10	29	40-70
HCEM26	M26X15	ED-26	16	21	12	32	60-100
HCEM27	M27X2	ED-27	16	21	12	32	100-135
HCEM33	M33X2	ED-33	16	22	17	40	150-240
HCEM42	M42X2	ED-42	16	22	22	50	260-360
HCEM48	M48X2	ED-48	16	22	24	55	300-400
HCEM60	M60X2	ED-60	18	26	27	70	380-450

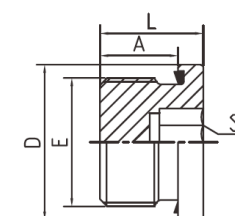

Nominal Holding Pressure

diameters mm	A356	2024-T4	EN-GJS-500	GJS-600	ETG-100
G1/8" - G3/4"	280BAR		320BAR		
G1/2" - G2-1/2"	220BAR		280BAR		
M8x1-M27x2	280BAR		320BAR		
M33-M60	220BAR		280BAR		

Hole preparation: if in doubt, contact our technical office

FC® "CLY" ED Plug

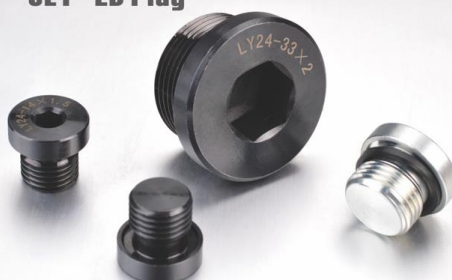

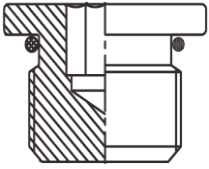

Sealed threaded plugs
320BAR/4300PSI
O-ring seal
Tempered steel
Surface oxidation treatment

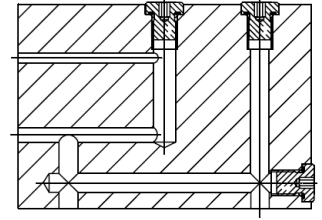

GAS

COD.	E thread	O-Ring Seal	A	L	S	D	Nm
HCOG02	G1/8"X28	7.8X1.9	8.6	11.6	5	14	10-15
HCOG04	G1/4"X19	10.8X2.4	11	15	6	19	25-35
HCOG06	G3/8 "X19	13.8X2.4	12	17	8	22	40-50
HCOG08	G1/2 "X14	17.8X2.4	15	19	10	27	72-82
HCOG12	G3/4"X14	23.7X3.5	16	21	12	32	85-100
HCOG16	G1"X11	28.7X3.5	19.2	23	17	40	120-160

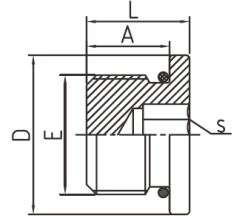

METRIC

COD.	E thread	O-Ring Seal	A	L	S	D	Nm
HCOM10	M10X1	81X1.6	8.5	11.5	5	14	10-12
HCOM12	M12X1.5	9.3X2.4	11	14	6	17	15-25
HCOM14	M14X1.5	11.3X2.4	11	14	6	19	20-35
HCOM16	M16X1.5	13.3X2.4	11.5	14	8	22	25-40
HCOM18	M18X1.5	15.3X2.4	12.5	15.5	8	24	30-45
HCOM20	M20X1.5	17.3X2.4	13	16	10	26	35-50
HCOM22	M22X1.5	19.3X2.4	13	16	10	27	40-70
HCOM27	M27X2	23.5X3.0	16	19	12	32	100-135
HCOM33	M33X2	29.5X3.0	16	20	17	40	150-240
HCOM42	M42X2	38.5X3.0	16	22	22	50	260-360
HCOM48	M48X2	44.5X3.0	17.5	21.5	24	55	300-400

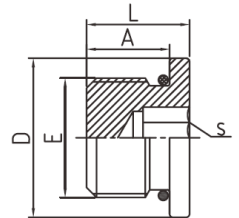

SAE

COD.	E thread	O-Ring Seal	A	L	S	D	Nm
HCOU02	5/16"X24UNF	6.07X1.63	8	10	3.2	11	15-20
HCOU03	3/8"X24UNF	7.65X1.87	8	10.2	4	12	15-20
HCOU04	7/16"X20UNF	8.92X1.83	9.1	11.5	5	14.5	20-35
HCOU05	1/2"X20UNF	10.52X1.83	9.1	11.5	5	16	30-40
HCOU06	9/16"X18UNF	11.89X1.98	9.7	12.2	6	17.5	35-45
HCOU08	3/4"X16UNF	16.36X2.21	11.1	14.3	8	22.2	45-60
HCOU10	7/8"X14UNF	19.18X2.46	12.7	16.2	10	25.4	55-75
HCOU12	1.1/16"X12UNF	23.47X2.95	15.1	19	14	32	75-90
HCOU16	1.5/16"X12UNF	29.74X2.95	15.1	19	16	81	100-160
HCOU20	15/8"X12UNF	37.46X3.00	15.1	19	19	47.6	150-210

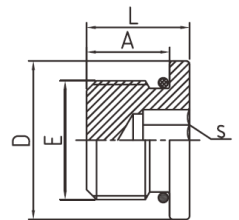

Nominal Holding Pressure					
diameters mm	A356	2024-T4	EN-GJS-500	GJS-600	ETG-100
G1/8" - G3/4"	280BAR		320BAR		
G1/2" - G2-1/2"	220BAR		280BAR		
M8x1-M27x2	280BAR		320BAR		
M33-M60	220BAR		280BAR		
5/16"-3/4"	280BAR		320BAR		
7/8"-15/8"	220BAR		280BAR		

Hole preparation: if in doubt, contact our technical office

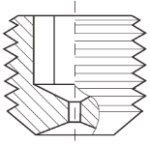

Restrictors – Flow restrictors

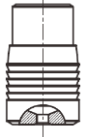

Threaded or expansion flow restrictors.
Metric threads, UN, NPTF, on request

The standard material is stainless steel AISI303 or copper
The diameter of the passage is on customer request

Threaded models can be easily replaced to adjust flow to customer calibration needs. Special models and other materials available on request

RT/RP

COD.	Thread	Hole +/-0.025mm	D1	L1	D2	L3	HEX
HCRT-040-XXX	M4	0.5-0.90	4	4	M4	4	2
HCRT-050-XXX	M5	0.50-1.40	5	5	M5	5	2.5
HCRT-060-XXX	M6	0.50-1.90	6	6	M6	6	3
HCRT-080-XXX	M8	0.50-2.90	8	8	M8	8	4
HCRT-100-XXX	M10	0.50-3.95	10	10	M10	10	5
HCRT-120-XXX	M12	0.50-4.95	12	12	M12	12	6

XXX: calibrated hole diameter e.g. 127=1.27mm

COD.	Thread	Hole +/-0.001"	D1	L1	D2	L3	HEX
HCRT-164-XXX	8-32	.020-.035	0.164	0.188	8-32	0.188	5/64
HCRT-190-XXX	10-32	.020-.050	0.190	0.188	10-32	0.188	3/32
HCRT-250-XXX	1/4-28	.020-.085	0.250	0.250	1/4-28	0.250	1/8
HCRT-312-XXX	5/16-24	.020-.115	0.312	0.313	5/16-24	0.313	5/32
HCRT-375-XXX	8/3-24	.020-.145	0.375	0.375	7/16-20	0.375	3/16
HCRT-437-XXX	7/8-20	.020-.175	0.437	0.375	1/2-20	0.375	7/32
HCRT-500-XXX	1/2-20	.020-.210	0.500	0.500		0.500	1/4

COD.	Thread	Hole +/-0.001"	D1	L1	D2	L3	HEX
HCRP-062-XXX	1/16-27NPTF	.020-.115	0.312	0.300	1/16-27 NPTF	0.300	5/32
HCRP-125-XXX	1/8-27 NPTF	.020-.145	0.405	0.300	1/8-27 NPTF	0.300	3/16
HCRP-250-XXX	1/4-18 NPTF	.020-.210	0.540	0.460	1/4-18 NPTF	0.460	1/4
HCRP-375-XXX	3/8-18NPTF	.020-.270	0.675	0.406	3/8-18 NPTF	0.406	5/16

XXX: calibrated hole diameter e.g. 050= 0.050"

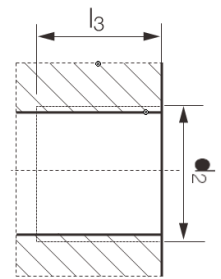
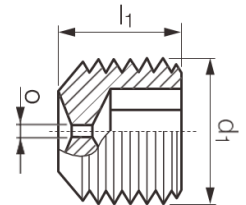

CRE

COD.	Hole +/-0.025mm	Q1	L1	L2	L3	D2 +0.1/-0	D3
CRE040-XXX	0.5-1.3	4	4	6	4	4	3.3
CRE050-XXX	0.5-1.9	5	5.5	8.2	5.5	5	4.3
CRE060-XXX	0.5-2.5	6	6.5	9.9	6.5	6	5.3
CRE070-XXX	0.5-3.3	7	7.5	11.6	7.5	7	6.2
CRE080-XXX	0.5-3.8	8	8.5	13.3	8.5	8	7.2
CRE090-XXX	0.5-4.3	9	10	15.5	10	9	8.2
CRE100-XXX	0.5-4.9	10	11	17.1	11	10	9.2
CRE120-XXX	0.5-6.1	12	13	20.5	13	12	11
CRE140-XXX	0.5-7.1	14	15	23.7	15	14	13

XXX: calibrated hole diameter e.g. 127=1.27mm

COD.	Hole +/-0.001"	Q1	L1	L2	L3	D2 +.039/-0	D3
CRE156-XXX	.02-.05	0.187	0.158	0.24	0.16	0.156	0.130
CRE187-XXX	.02-.07	0.218	0.217	0.31	0.22	0.187	0.160
CRE218-XXX	.02-.085	0.218	0.217	0.33	0.22	0.281	0.190
CRE250-XXX	.02-.105	0.250	0.256	0.40	0.26	0.250	0.220
CRE281-XXX	.02-.13	0.281	0.296	0.46	0.30	0.281	0.250
CRE312-XXX	.02-.15	0.312	0.335	0.52	0.34	0.312	0.281
CRE343-XXX	.02-.16	0.343	0.394	0.60	0.40	0.343	0.312
CRE375-XXX	.02-.18	0.375	0.394	0.62	0.40	0.375	0.343
CRE406-XXX	.02-.195	0.406	0.434	0.67	0.44	0.406	0.375
CRE437-XXX	.02-.22	0.437	0.512	0.77	0.52	0.437	0.406
CRE468-XXX	.02-.24	0.468	0.512	0.81	0.52	0.468	0.437
CRE562-XXX	.02-.29	0.562	0.591	0.94	0.60	0.562	0.510

XXX: calibrated hole diameter e.g. 050= 0.050"

HOLDING PRESSURE: 280BAR

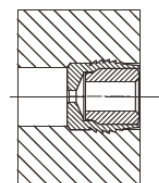
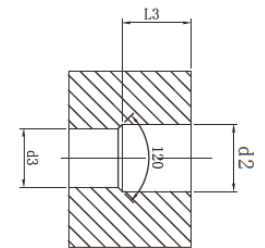
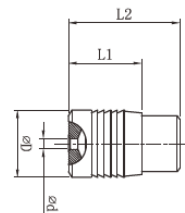

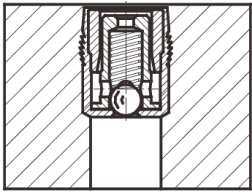

CVH – Mini Check Valve - 350Bar

Mini Flow Control Valves

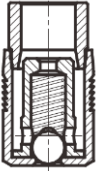

Expansion Check Valve

100% tested – max leakage 15cc/min

Standard material AISI303, other materials on request

Reliable and accurate in high frequency applications

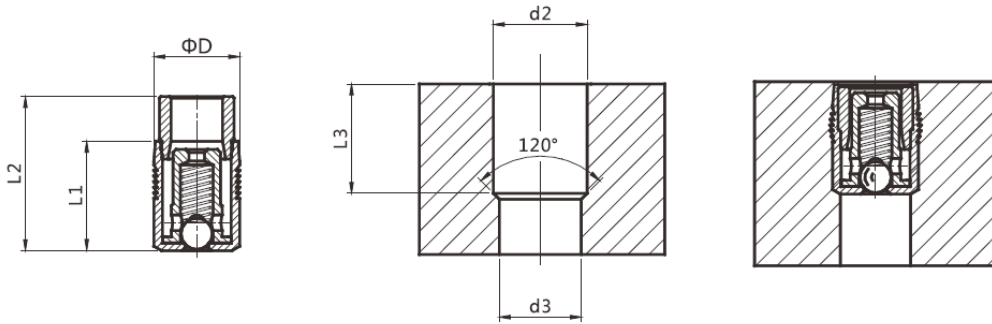

PZ

COD.	Model	D 0/-0.05	L1	L2	L3	D2 +0.1/-0	D3
PL430101M-XX	PZ5.5	5.5	7	10	7.5	5.5	4.7
PL430102M-XX	PZ8.0	8	10	14.3	10.5	8	7.2
PL430103M-XX	PZ10	10	14	20	14.5	10	8.0

XXX: opening bar e.g. 050=0.50Bars

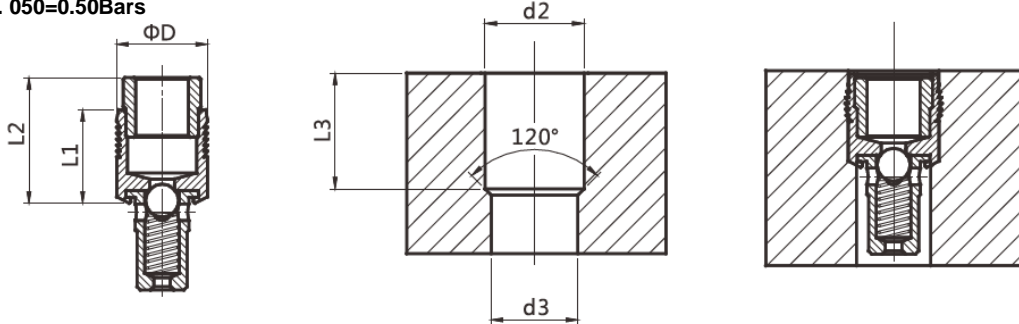

PF

COD.	Model	D 0/-0.05	L1	L2	L3	D2 +0.1/-0	D3
PL530101M-XX	PF5.5	5.5	5.5	7.5	6	5.5	4.7
PL530102M-XX	PF8.0	8	10	14.3	10.5	8	7.2
PL530103M-XX	PF10	10	14	20	14.5	10	8.0

XXX: opening bar e.g. 050=0.50Bars

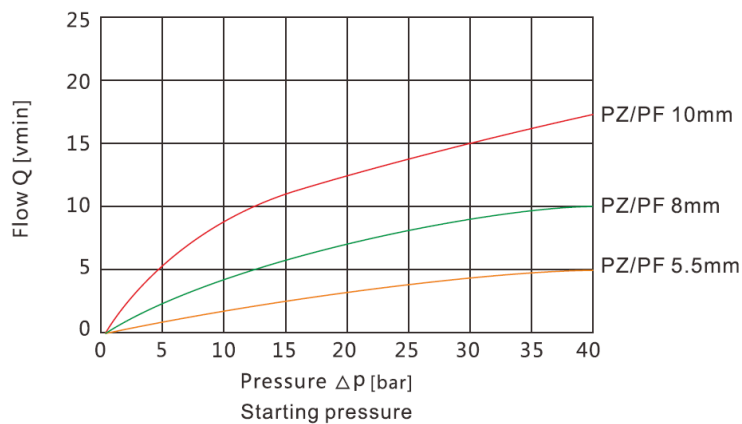

FC® "CVH" Check Valve



CVP - SHV – Mini Check Valve - 350Bar

Mini Flow Control Valves

100% tested – max leakage 15cc/min

Standard material AISI303 stainless steel, other materials on request
Reliable and accurate in high frequency applications

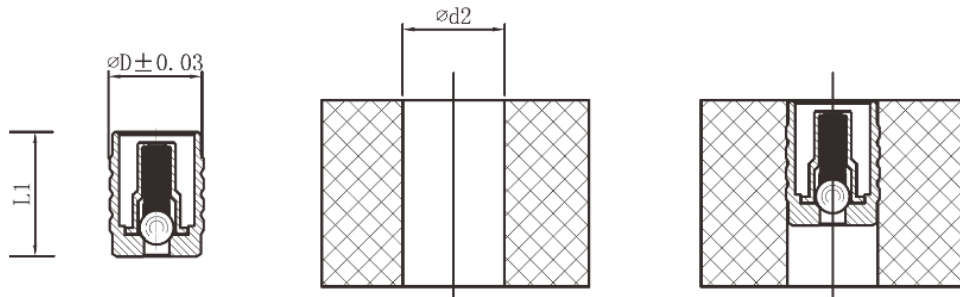

CV

COD.	Model	D	L1	D2 +/-0.04
CV5505-XX	CVP5.5	5.46	7.3	5.32
CV5508-XX	CVP8.0	7.92	10.1	7.78

XXX: opening bar e.g. 050=0.50Bars

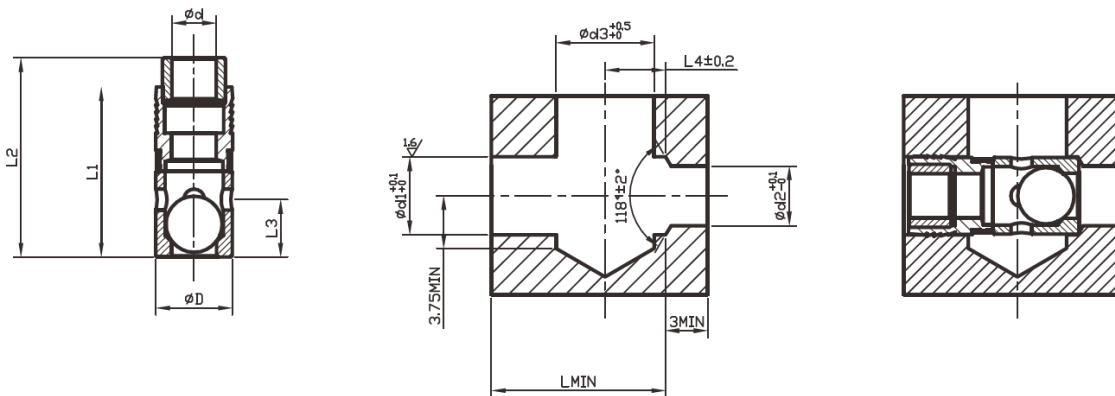

SHV extension

COD.	Model	D	L1	L2	L3	d	d1	d2	d3	L	L4
SHV100101-XX	SHV5.5	5.46	12.2	14.5	4.1	3.15	5.55	4.25	7	12.4	4.3

XXX: opening bar e.g. 050=0.50Bars

FC®
"CVH" Check Valve





The solution
for
Sealing and fluid control



The solution
for
Sealing and fluid control

