

Grippex[®] Mini - Instructions for disassembling / assembling of fingers

Remark: The new fingers can be mounted using this instruction backwards.

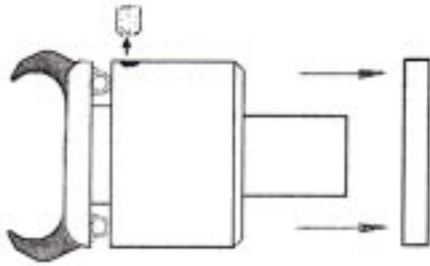

1. Unscrew the Valve-screw and remove the cover.

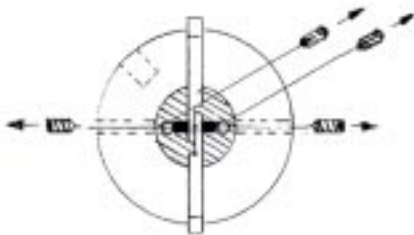

2. Unscrew the two screws on the body and the two stop-screws on the front of the shaft.

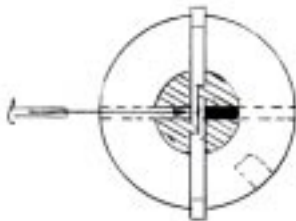

3. Put the pin aside, out of the holes of the fingers.

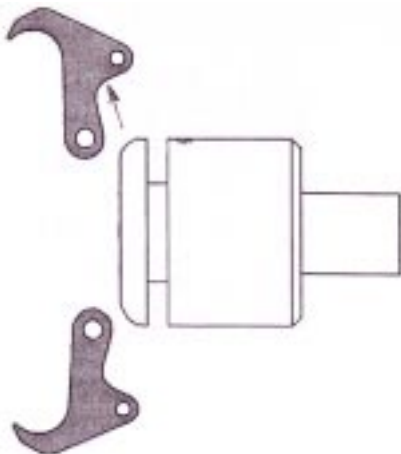

4. The fingers will be released and can be removed.