

STEINER™

INGENIOUS CUTTING TOOLS

Stocked Flywheel Autofacer®

THE WORLD LEADER IN

AUTOMATIC BACK BORING SOLUTIONS

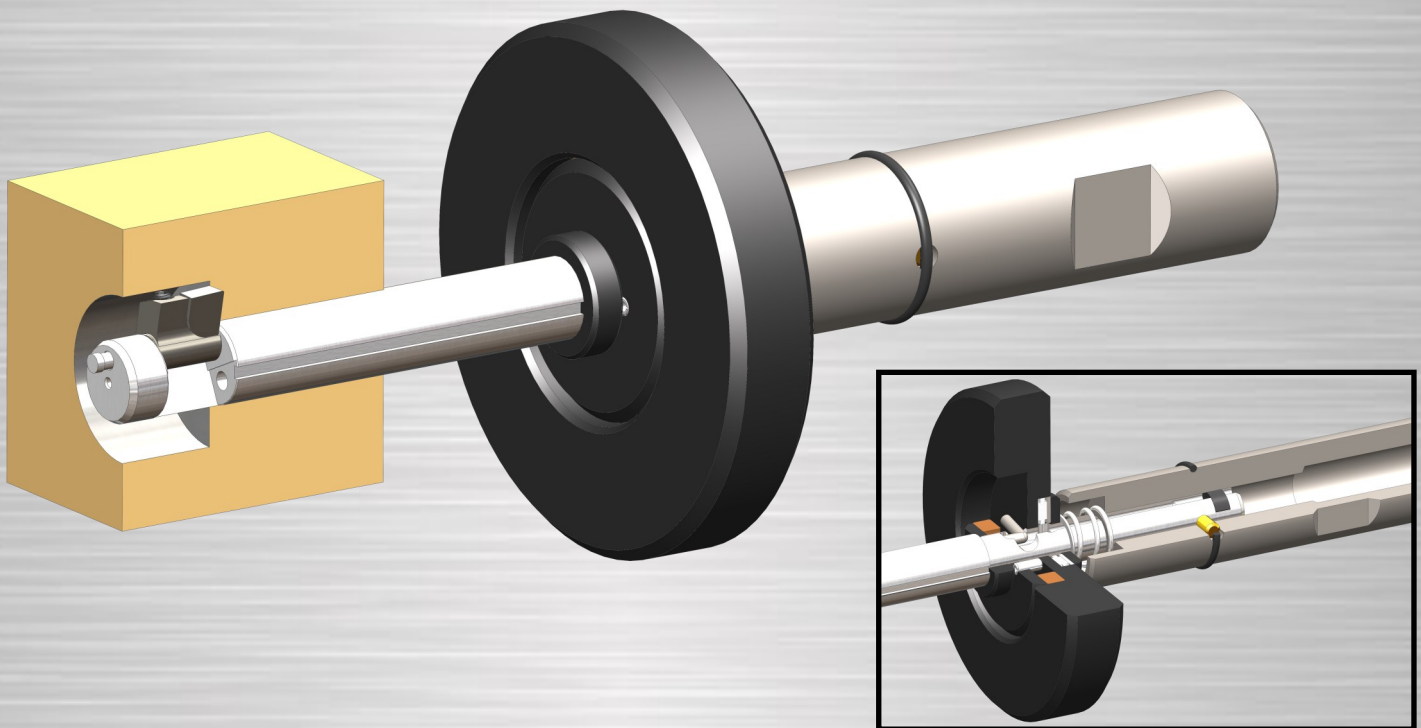

Advantages:

- **Inch & Metric Weldon Shanks available.**
- **Fully supported in pilot hole during cutting.**
- **Utilizes machine spindle inertia to open/close.**
- **Shear pin design protects the tool investment, workpiece and machine spindle.**



Counterbore Ø | 9.5mm (0.375in) - 15.5mm (0.610in)

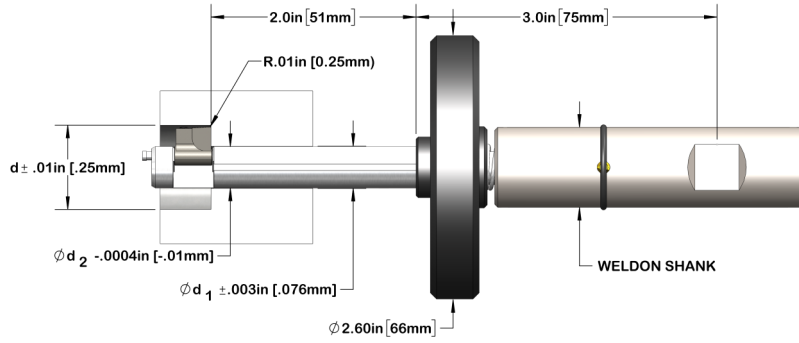

Counterbore		Pilot Hole		Autofacer		Order Number		
d (mm)	d (in)	d₁ (mm)	d₁ (in)	d₂ (mm)	d₂ (in)	Weldon Shank	Autofacer P/N	Cutter Blade P/N
9.5	0.374	6.5	0.256	6.4	0.251	Ø20mm	AF25-6.50M	CB25-9.50M
		6.5	0.256	6.4	0.251	Ø0.75in	AF25-6.50	
		7.0	0.276	6.9	0.270	Ø20mm	AF25-7.00M	
		7.0	0.276	6.9	0.270	Ø0.75in	AF25-7.00	
10.0	0.394	6.5	0.256	6.4	0.251	Ø20mm	AF25-6.50M	CB25-10.00M
		6.5	0.256	6.4	0.251	Ø0.75in	AF25-6.50	
		7.0	0.276	6.9	0.270	Ø20mm	AF25-7.00M	
		7.0	0.276	6.9	0.270	Ø0.75in	AF25-7.00	
10.5	0.413	6.5	0.256	6.4	0.251	Ø20mm	AF25-6.50M	CB25-10.50M
		6.5	0.256	6.4	0.251	Ø0.75in	AF25-6.50	
		7.0	0.276	6.9	0.270	Ø20mm	AF25-7.00M	
		7.0	0.276	6.9	0.270	Ø0.75in	AF25-7.00	
11.0	0.433	6.5	0.256	6.4	0.251	Ø20mm	AF25-6.50M	CB25-11.00M
		6.5	0.256	6.4	0.251	Ø0.75in	AF25-6.50	
		7.0	0.276	6.9	0.270	Ø20mm	AF25-7.00M	
		7.0	0.276	6.9	0.270	Ø0.75in	AF25-7.00	
11.0	0.433	7.5	0.295	7.4	0.290	Ø20mm	AF28-7.50M	CB28-11.00M
		7.5	0.295	7.4	0.290	Ø0.75in	AF28-7.50	
		7.5	0.295	6.4	0.251	Ø20mm	AF25-6.50M	
		7.5	0.295	6.4	0.251	Ø0.75in	AF25-6.50	
11.5	0.453	7.0	0.276	6.9	0.270	Ø20mm	AF25-7.00M	CB25-11.50M
		7.5	0.295	7.4	0.290	Ø20mm	AF28-7.50M	
		7.5	0.295	7.4	0.290	Ø0.75in	AF28-7.50	
		8.0	0.315	7.9	0.310	Ø20mm	AF31-8.00M	
11.5	0.453	8.0	0.315	7.9	0.310	Ø0.75in	AF31-8.00	CB31-11.50M
		8.5	0.335	8.4	0.330	Ø20mm	AF31-8.50M	
		8.5	0.335	8.4	0.330	Ø0.75in	AF31-8.50	
		8.5	0.335	8.4	0.330	Ø20mm	AF31-8.50M	
12.0	0.472	6.5	0.256	6.4	0.251	Ø20mm	AF25-6.50M	CB25-12.00M
		6.5	0.256	6.4	0.251	Ø0.75in	AF25-6.50	
		7.0	0.276	6.9	0.270	Ø20mm	AF25-7.00M	
		7.0	0.276	6.9	0.270	Ø0.75in	AF25-7.00	
12.0	0.472	7.5	0.295	7.4	0.290	Ø20mm	AF28-7.50M	CB28-12.00M
		7.5	0.295	7.4	0.290	Ø0.75in	AF28-7.50	
		8.0	0.315	7.9	0.310	Ø20mm	AF31-8.00M	
		8.0	0.315	7.9	0.310	Ø0.75in	AF31-8.00	
12.0	0.472	8.5	0.335	8.4	0.330	Ø20mm	AF31-8.50M	CB31-12.00M
		8.5	0.335	8.4	0.330	Ø0.75in	AF31-8.50	
		8.5	0.335	8.4	0.330	Ø20mm	AF31-8.50M	
		8.5	0.335	8.4	0.330	Ø0.75in	AF31-8.50	
12.5	0.492	6.5	0.256	6.4	0.251	Ø20mm	AF25-6.50M	CB25-12.50M
		6.5	0.256	6.4	0.251	Ø0.75in	AF25-6.50	
		7.0	0.276	6.9	0.270	Ø20mm	AF25-7.00M	
		7.0	0.276	6.9	0.270	Ø0.75in	AF25-7.00	
12.5	0.492	7.5	0.295	7.4	0.290	Ø20mm	AF28-7.50M	CB28-12.50M
		7.5	0.295	7.4	0.290	Ø0.75in	AF28-7.50	
		8.0	0.315	7.9	0.310	Ø20mm	AF31-8.00M	
		8.0	0.315	7.9	0.310	Ø0.75in	AF31-8.00	
12.5	0.492	8.5	0.335	8.4	0.330	Ø20mm	AF31-8.50M	CB31-12.50M
		8.5	0.335	8.4	0.330	Ø0.75in	AF31-8.50	
		8.5	0.335	8.4	0.330	Ø20mm	AF31-8.50M	
		8.5	0.335	8.4	0.330	Ø0.75in	AF31-8.50	
13.0	0.512	6.5	0.256	6.4	0.251	Ø20mm	AF25-6.50M	CB25-13.00M
		6.5	0.256	6.4	0.251	Ø0.75in	AF25-6.50	
		7.0	0.276	6.9	0.270	Ø20mm	AF25-7.00M	
		7.0	0.276	6.9	0.270	Ø0.75in	AF25-7.00	
13.0	0.512	7.5	0.295	7.4	0.290	Ø20mm	AF28-7.50M	CB28-13.00M
		7.5	0.295	7.4	0.290	Ø0.75in	AF28-7.50	
		8.0	0.315	7.9	0.310	Ø20mm	AF31-8.00M	
		8.0	0.315	7.9	0.310	Ø0.75in	AF31-8.00	
13.0	0.512	8.5	0.335	8.4	0.330	Ø20mm	AF31-8.50M	CB31-13.00M
		8.5	0.335	8.4	0.330	Ø0.75in	AF31-8.50	
		8.5	0.335	8.4	0.330	Ø20mm	AF31-8.50M	
		8.5	0.335	8.4	0.330	Ø0.75in	AF31-8.50	
13.5	0.531	7.5	0.295	7.4	0.290	Ø20mm	AF28-7.50M	CB28-13.50M
		7.5	0.295	7.4	0.290	Ø0.75in	AF28-7.50	
		8.0	0.315	7.9	0.310	Ø20mm	AF31-8.00M	
		8.0	0.315	7.9	0.310	Ø0.75in	AF31-8.00	
13.5	0.531	8.5	0.335	8.4	0.330	Ø20mm	AF31-8.50M	CB31-13.50M
		8.5	0.335	8.4	0.330	Ø0.75in	AF31-8.50	
		9.0	0.354	8.9	0.349	Ø20mm	AF34-9.00M	
		9.0	0.354	8.9	0.349	Ø0.75in	AF34-9.00	
13.5	0.531	9.5	0.374	9.4	0.369	Ø20mm	AF38-9.50M	CB38-13.50M
		9.5	0.374	9.4	0.369	Ø0.75in	AF38-9.50	
		10.0	0.394	9.9	0.389	Ø20mm	AF38-10.00M	
		10.0	0.394	9.9	0.389	Ø0.75in	AF38-10.00	
14.0	0.551	7.5	0.295	7.4	0.290	Ø20mm	AF28-7.50M	CB28-14.00M
		7.5	0.295	7.4	0.290	Ø0.75in	AF28-7.50	
		8.0	0.315	7.9	0.310	Ø20mm	AF31-8.00M	
		8.0	0.315	7.9	0.310	Ø0.75in	AF31-8.00	
14.0	0.551	8.5	0.335	8.4	0.330	Ø20mm	AF31-8.50M	CB31-14.00M
		8.5	0.335	8.4	0.330	Ø0.75in	AF31-8.50	
		9.0	0.354	8.9	0.349	Ø20mm	AF34-9.00M	
		9.0	0.354	8.9	0.349	Ø0.75in	AF34-9.00	
14.0	0.551	9.5	0.374	9.4	0.369	Ø20mm	AF38-9.50M	CB38-14.00M
		9.5	0.374	9.4	0.369	Ø0.75in	AF38-9.50	
		10.0	0.394	9.9	0.389	Ø20mm	AF38-10.00M	
		10.0	0.394	9.9	0.389	Ø0.75in	AF38-10.00	
14.5	0.571	8.0	0.315	7.9	0.310	Ø20mm	AF31-8.00M	CB31-14.50M
		8.0	0.315	7.9	0.310	Ø0.75in	AF31-8.00	
		8.5	0.335	8.4	0.330	Ø20mm	AF31-8.50M	
		8.5	0.335	8.4	0.330	Ø0.75in	AF31-8.50	
14.5	0.571	9.0	0.354	8.9	0.349	Ø20mm	AF34-9.00M	CB34-14.50M
		9.0	0.354	8.9	0.349	Ø0.75in	AF34-9.00	
		9.5	0.374	9.4	0.369	Ø20mm	AF38-9.50M	
		9.5	0.374	9.4	0.369	Ø0.75in	AF38-9.50	
14.5	0.571	10.0	0.394	9.9	0.389	Ø20mm	AF38-10.00M	CB38-14.50M
		10.0	0.394	9.9	0.389	Ø0.75in	AF38-10.00	
		10.0	0.394	9.9	0.389	Ø20mm	AF38-10.00M	
		10.0	0.394	9.9	0.389	Ø0.75in	AF38-10.00	
15.0	0.591	8.0	0.315	7.9	0.310	Ø20mm	AF31-8.00M	CB31-15.00M
		8.0	0.315	7.9	0.310	Ø0.75in	AF31-8.00	
		8.5	0.335	8.4	0.330	Ø20mm	AF31-8.50M	
		8.5	0.335	8.4	0.330	Ø0.75in	AF31-8.50	
15.0	0.591	9.0	0.354	8.9	0.349	Ø20mm	AF34-9.00M	CB34-15.00M
		9.0	0.354	8.9	0.349	Ø0.75in	AF34-9.00	
		9.5	0.374	9.4	0.369	Ø20mm	AF38-9.50M	
		9.5	0.374	9.4	0.369	Ø0.75in	AF38-9.50	
15.0	0.591	10.0	0.394	9.9	0.389	Ø20mm	AF38-10.00M	CB38-15.00M
		10.0	0.394	9.9	0.389	Ø0.75in	AF38-10.00	
		10.0	0.394	9.9	0.389	Ø20mm	AF38-10.00M	
		10.0	0.394	9.9	0.389	Ø0.75in	AF38-10.00	
15.5	0.610	8.0	0.315	7.9	0.310	Ø20mm	AF31-8.00M	CB31-15.50M
		8.0	0.315	7.9	0.310	Ø0.75in	AF31-8.00	
		8.5	0.335	8.4	0.330	Ø20mm	AF31-8.50M	
		8.5	0.335	8.4	0.330	Ø0.75in	AF31-8.50	
15.5	0.610	9.0	0.354	8.9	0.349	Ø20mm	AF34-9.00M	CB34-15.50M
		9.0	0.354	8.9	0.349	Ø0.75in	AF34-9.00	
		9.5	0.374	9.4	0.369	Ø20mm	AF38-9.50M	
		9.5	0.374	9.4	0.369	Ø0.75in	AF38-9.50	
15.5	0.610	10.0	0.394	9.9	0.389	Ø20mm	AF38-10.00M	CB38-15.50M
		10.0	0.394	9.9	0.389	Ø0.75in	AF38-10.00	
		10.0	0.394	9.9	0.389	Ø20mm	AF38-10.00M	
		10.0	0.394	9.9	0.389	Ø0.75in	AF38-10.00	
15.5	0.610	10.5	0.413	10.4	0.408	Ø20mm	AF40-10.50M	CB40-15.50M
		10.5	0.413	10.4	0.408	Ø0.75in	AF40-10.50	
		11.0	0.433	10.9	0.428	Ø20mm	AF40-11.00M	
		11.0	0.433	10.9	0.428	Ø0.75in	AF40-11.00	

Counterbore Ø | 16mm (0.630in) - 19mm (0.748in)

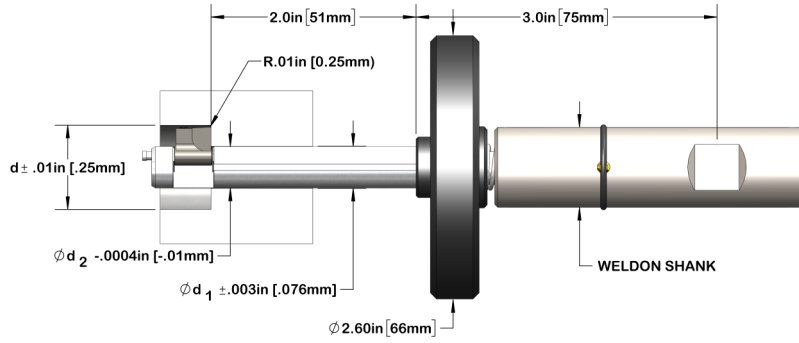

Counterbore		Pilot Hole		Autofacer		Order Number		
d (mm)	d (in)	d ₁ (mm)	d ₁ (in)	d ₂ (mm)	d ₂ (in)	Weldon Shank	Autofacer P/N	Cutter Blade P/N
16.0	0.630	8.0	0.315	7.9	0.310	Ø20mm	AF31-8.00M	CB31-16.00M
		8.0	0.315	7.9	0.310	Ø0.75in	AF31-8.00	
		8.5	0.335	8.4	0.330	Ø20mm	AF31-8.50M	
		8.5	0.335	8.4	0.330	Ø0.75in	AF31-8.50	
		9.0	0.354	8.9	0.349	Ø20mm	AF34-9.00M	CB34-16.00M
		9.0	0.354	8.9	0.349	Ø0.75in	AF34-9.00	
		9.5	0.374	9.4	0.369	Ø20mm	AF38-9.50M	CB38-16.00M
		9.5	0.374	9.4	0.369	Ø0.75in	AF38-9.50	
		10.0	0.394	9.9	0.389	Ø20mm	AF38-10.00M	
		10.0	0.394	9.9	0.389	Ø0.75in	AF38-10.00	
		10.5	0.413	10.4	0.408	Ø20mm	AF40-10.50M	CB40-16.00M
		10.5	0.413	10.4	0.408	Ø0.75in	AF40-10.50	
11.0	0.433	10.9	0.428	Ø20mm	AF40-11.00M			
11.0	0.433	10.9	0.428	Ø0.75in	AF40-11.00			
16.5	0.650	9.0	0.354	8.9	0.349	Ø20mm	AF34-9.00M	CB34-16.50M
		9.0	0.354	8.9	0.349	Ø0.75in	AF34-9.00	
		9.5	0.374	9.4	0.369	Ø20mm	AF38-9.50M	CB38-16.50M
		9.5	0.374	9.4	0.369	Ø0.75in	AF38-9.50	
		10.0	0.394	9.9	0.389	Ø20mm	AF38-10.00M	
		10.0	0.394	9.9	0.389	Ø0.75in	AF38-10.00	
		10.5	0.413	10.4	0.408	Ø20mm	AF40-10.50M	CB40-16.50M
		10.5	0.413	10.4	0.408	Ø0.75in	AF40-10.50	
		11.0	0.433	10.9	0.428	Ø20mm	AF40-11.00M	
		11.0	0.433	10.9	0.428	Ø0.75in	AF40-11.00	
		11.5	0.453	11.4	0.448	Ø20mm	AF44-11.50M	CB44-16.50M
		11.5	0.453	11.4	0.448	Ø0.75in	AF44-11.50	
17.0	0.669	9.0	0.354	8.9	0.349	Ø20mm	AF34-9.00M	CB34-17.00M
		9.0	0.354	8.9	0.349	Ø0.75in	AF34-9.00	
		9.5	0.374	9.4	0.369	Ø20mm	AF38-9.50M	CB38-17.00M
		9.5	0.374	9.4	0.369	Ø0.75in	AF38-9.50	
		10.0	0.394	9.9	0.389	Ø20mm	AF38-10.00M	
		10.0	0.394	9.9	0.389	Ø0.75in	AF38-10.00	
		10.5	0.413	10.4	0.408	Ø20mm	AF40-10.50M	CB40-17.00M
		10.5	0.413	10.4	0.408	Ø0.75in	AF40-10.50	
		11.0	0.433	10.9	0.428	Ø20mm	AF40-11.00M	
		11.0	0.433	10.9	0.428	Ø0.75in	AF40-11.00	
		11.5	0.453	11.4	0.448	Ø20mm	AF44-11.50M	CB44-17.00M
		11.5	0.453	11.4	0.448	Ø0.75in	AF44-11.50	
17.5	0.689	9.0	0.354	8.9	0.349	Ø20mm	AF34-9.00M	CB34-17.50M
		9.0	0.354	8.9	0.349	Ø0.75in	AF34-9.00	
		9.5	0.374	9.4	0.369	Ø20mm	AF38-9.50M	CB38-17.50M
		9.5	0.374	9.4	0.369	Ø0.75in	AF38-9.50	
		10.0	0.394	9.9	0.389	Ø20mm	AF38-10.00M	
		10.0	0.394	9.9	0.389	Ø0.75in	AF38-10.00	
		10.5	0.413	10.4	0.408	Ø20mm	AF40-10.50M	CB40-17.50M
		10.5	0.413	10.4	0.408	Ø0.75in	AF40-10.50	
		11.0	0.433	10.9	0.428	Ø20mm	AF40-11.00M	
		11.0	0.433	10.9	0.428	Ø0.75in	AF40-11.00	
		11.5	0.453	11.4	0.448	Ø20mm	AF44-11.50M	CB44-17.50M
		11.5	0.453	11.4	0.448	Ø0.75in	AF44-11.50	

Counterbore		Pilot Hole		Autofacer		Order Number				
d (mm)	d (in)	d ₁ (mm)	d ₁ (in)	d ₂ (mm)	d ₂ (in)	Weldon Shank	Autofacer P/N	Cutter Blade P/N		
18.0	0.709	9.0	0.354	8.9	0.349	Ø20mm	AF34-9.00M	CB34-18.00M		
		9.0	0.354	8.9	0.349	Ø0.75in	AF34-9.00			
		9.5	0.374	9.4	0.369	Ø20mm	AF38-9.50M		CB38-18.00M	
		9.5	0.374	9.4	0.369	Ø0.75in	AF38-9.50			
		10.0	0.394	9.9	0.389	Ø20mm	AF38-10.00M	CB40-18.00M		
		10.0	0.394	9.9	0.389	Ø0.75in	AF38-10.00			
		10.5	0.413	10.4	0.408	Ø20mm	AF40-10.50M			
		10.5	0.413	10.4	0.408	Ø0.75in	AF40-10.50			
		11.0	0.433	10.9	0.428	Ø20mm	AF40-11.00M	CB44-18.00M		
		11.0	0.433	10.9	0.428	Ø0.75in	AF40-11.00			
		11.5	0.453	11.4	0.448	Ø20mm	AF44-11.50M			
		11.5	0.453	11.4	0.448	Ø0.75in	AF44-11.50			
18.5	0.728	9.5	0.374	9.4	0.369	Ø20mm	AF38-9.50M	CB38-18.50M		
		9.5	0.374	9.4	0.369	Ø0.75in	AF38-9.50			
		10.0	0.394	9.9	0.389	Ø20mm	AF38-10.00M	CB40-18.50M		
		10.0	0.394	9.9	0.389	Ø0.75in	AF38-10.00			
		10.5	0.413	10.4	0.408	Ø20mm	AF40-10.50M			
		10.5	0.413	10.4	0.408	Ø0.75in	AF40-10.50			
		11.0	0.433	10.9	0.428	Ø20mm	AF40-11.00M	CB44-18.50M		
		11.0	0.433	10.9	0.428	Ø0.75in	AF40-11.00			
		11.5	0.453	11.4	0.448	Ø20mm	AF44-11.50M			
		11.5	0.453	11.4	0.448	Ø0.75in	AF44-11.50			
		19.0	0.748	12.0	0.472	11.9	0.467	Ø20mm	AF47-12.00M	CB47-18.50M
				12.0	0.472	11.9	0.467	Ø0.75in	AF47-12.00	
12.5	0.492			12.4	0.487	Ø20mm	AF50-12.50M	CB50-18.50M		
12.5	0.492			12.4	0.487	Ø0.75in	AF50-12.50			
13.0	0.512			12.9	0.507	Ø20mm	AF50-13.00M			
13.0	0.512			12.9	0.507	Ø0.75in	AF50-13.00			
10.5	0.413			10.4	0.408	Ø20mm	AF40-10.50M	CB40-19.00M		
10.5	0.413			10.4	0.408	Ø0.75in	AF40-10.50			
11.0	0.433			10.9	0.428	Ø20mm	AF40-11.00M			
11.0	0.433			10.9	0.428	Ø0.75in	AF40-11.00			
11.5	0.453			11.4	0.448	Ø20mm	AF44-11.50M	CB44-19.00M		
11.5	0.453			11.4	0.448	Ø0.75in	AF44-11.50			
12.0	0.472	11.9	0.467	Ø20mm	AF47-12.00M					
12.0	0.472	11.9	0.467	Ø0.75in	AF47-12.00					
12.5	0.492	12.4	0.487	Ø20mm	AF50-12.50M	CB50-19.00M				
12.5	0.492	12.4	0.487	Ø0.75in	AF50-12.50					
13.0	0.512	12.9	0.507	Ø20mm	AF50-13.00M					
13.0	0.512	12.9	0.507	Ø0.75in	AF50-13.00					

Counterbore Ø | 19.5mm (0.768in) - 22mm (0.866in)

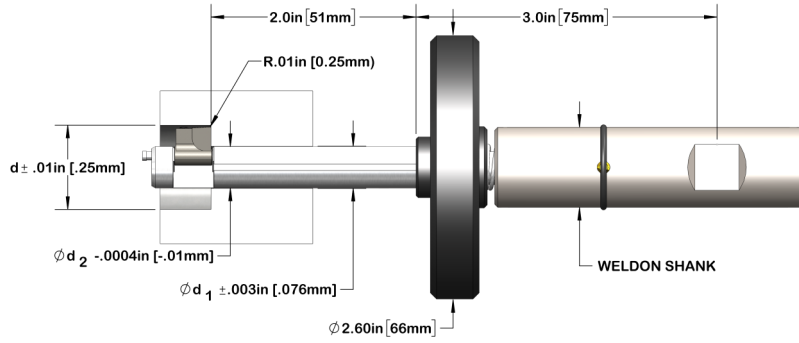

Counterbore		Pilot Hole		Autofacer		Order Number		
d (mm)	d (in)	d ₁ (mm)	d ₁ (in)	d ₂ (mm)	d ₂ (in)	Weldon Shank	Autofacer P/N	Cutter Blade P/N
19.5	0.768	10.5	0.413	10.4	0.408	Ø20mm	AF40-10.50M	CB40-19.50M
		10.5	0.413	10.4	0.408	Ø0.75in	AF40-10.50	
		11.0	0.433	10.9	0.428	Ø20mm	AF40-11.00M	
		11.0	0.433	10.9	0.428	Ø0.75in	AF40-11.00	
		11.5	0.453	11.4	0.448	Ø20mm	AF44-11.50M	CB44-19.50M
		11.5	0.453	11.4	0.448	Ø0.75in	AF44-11.50	
		12.0	0.472	11.9	0.467	Ø20mm	AF47-12.00M	CB47-19.50M
		12.0	0.472	11.9	0.467	Ø0.75in	AF47-12.00	
		12.5	0.492	12.4	0.487	Ø20mm	AF50-12.50M	CB50-19.50M
		12.5	0.492	12.4	0.487	Ø0.75in	AF50-12.50	
		13.0	0.512	12.9	0.507	Ø20mm	AF50-13.00M	
		13.0	0.512	12.9	0.507	Ø0.75in	AF50-13.00	
		13.5	0.531	13.4	0.526	Ø20mm	AF53-13.50M	CB53-19.50M
		13.5	0.531	13.4	0.526	Ø0.75in	AF53-13.50	
14.0	0.551	13.9	0.546	Ø20mm	AF53-14.00M			
14.0	0.551	13.9	0.546	Ø0.75in	AF53-14.00			
20.0	0.787	10.5	0.413	10.4	0.408	Ø20mm	AF40-10.50M	CB40-20.00M
		10.5	0.413	10.4	0.408	Ø0.75in	AF40-10.50	
		11.0	0.433	10.9	0.428	Ø20mm	AF40-11.00M	
		11.0	0.433	10.9	0.428	Ø0.75in	AF40-11.00	
		11.5	0.453	11.4	0.448	Ø20mm	AF44-11.50M	CB44-20.00M
		11.5	0.453	11.4	0.448	Ø0.75in	AF44-11.50	
		12.0	0.472	11.9	0.467	Ø20mm	AF47-12.00M	CB47-20.00M
		12.0	0.472	11.9	0.467	Ø0.75in	AF47-12.00	
		12.5	0.492	12.4	0.487	Ø20mm	AF50-12.50M	CB50-20.00M
		12.5	0.492	12.4	0.487	Ø0.75in	AF50-12.50	
		13.0	0.512	12.9	0.507	Ø20mm	AF50-13.00M	
		13.0	0.512	12.9	0.507	Ø0.75in	AF50-13.00	
		13.5	0.531	13.4	0.526	Ø20mm	AF53-13.50M	CB53-20.00M
		13.5	0.531	13.4	0.526	Ø0.75in	AF53-13.50	
14.0	0.551	13.9	0.546	Ø20mm	AF53-14.00M			
14.0	0.551	13.9	0.546	Ø0.75in	AF53-14.00			
20.5	0.807	10.5	0.413	10.4	0.408	Ø20mm	AF40-10.50M	CB40-20.50M
		10.5	0.413	10.4	0.408	Ø0.75in	AF40-10.50	
		11.0	0.433	10.9	0.428	Ø20mm	AF40-11.00M	
		11.0	0.433	10.9	0.428	Ø0.75in	AF40-11.00	
		11.5	0.453	11.4	0.448	Ø20mm	AF44-11.50M	CB44-20.50M
		11.5	0.453	11.4	0.448	Ø0.75in	AF44-11.50	
		12.0	0.472	11.9	0.467	Ø20mm	AF47-12.00M	CB47-20.50M
		12.0	0.472	11.9	0.467	Ø0.75in	AF47-12.00	
		12.5	0.492	12.4	0.487	Ø20mm	AF50-12.50M	CB50-20.50M
		12.5	0.492	12.4	0.487	Ø0.75in	AF50-12.50	
		13.0	0.512	12.9	0.507	Ø20mm	AF50-13.00M	
		13.0	0.512	12.9	0.507	Ø0.75in	AF50-13.00	
		13.5	0.531	13.4	0.526	Ø20mm	AF53-13.50M	CB53-20.50M
		13.5	0.531	13.4	0.526	Ø0.75in	AF53-13.50	
14.0	0.551	13.9	0.546	Ø20mm	AF53-14.00M			
14.0	0.551	13.9	0.546	Ø0.75in	AF53-14.00			

Counterbore		Pilot Hole		Autofacer		Order Number		
d (mm)	d (in)	d ₁ (mm)	d ₁ (in)	d ₂ (mm)	d ₂ (in)	Weldon Shank	Autofacer P/N	Cutter Blade P/N
21.0	0.827	10.5	0.413	10.4	0.408	Ø20mm	AF40-10.50M	CB40-21.00M
		10.5	0.413	10.4	0.408	Ø0.75in	AF40-10.50	
		11.0	0.433	10.9	0.428	Ø20mm	AF40-11.00M	
		11.0	0.433	10.9	0.428	Ø0.75in	AF40-11.00	
		11.5	0.453	11.4	0.448	Ø20mm	AF44-11.50M	CB44-21.00M
		11.5	0.453	11.4	0.448	Ø0.75in	AF44-11.50	
		12.0	0.472	11.9	0.467	Ø20mm	AF47-12.00M	CB47-21.00M
		12.0	0.472	11.9	0.467	Ø0.75in	AF47-12.00	
		12.5	0.492	12.4	0.487	Ø20mm	AF50-12.50M	CB50-21.00M
		12.5	0.492	12.4	0.487	Ø0.75in	AF50-12.50	
		13.0	0.512	12.9	0.507	Ø20mm	AF50-13.00M	
		13.0	0.512	12.9	0.507	Ø0.75in	AF50-13.00	
		13.5	0.531	13.4	0.526	Ø20mm	AF53-13.50M	CB53-21.00M
		13.5	0.531	13.4	0.526	Ø0.75in	AF53-13.50	
14.0	0.551	13.9	0.546	Ø20mm	AF53-14.00M			
14.0	0.551	13.9	0.546	Ø0.75in	AF53-14.00			
21.5	0.846	11.5	0.453	11.4	0.448	Ø20mm	AF44-11.50M	CB44-21.50M
		11.5	0.453	11.4	0.448	Ø0.75in	AF44-11.50	
		12.0	0.472	11.9	0.467	Ø20mm	AF47-12.00M	CB47-21.50M
		12.0	0.472	11.9	0.467	Ø0.75in	AF47-12.00	
		12.5	0.492	12.4	0.487	Ø20mm	AF50-12.50M	CB50-21.50M
		12.5	0.492	12.4	0.487	Ø0.75in	AF50-12.50	
		13.0	0.512	12.9	0.507	Ø20mm	AF50-13.00M	
		13.0	0.512	12.9	0.507	Ø0.75in	AF50-13.00	
		13.5	0.531	13.4	0.526	Ø20mm	AF53-13.50M	CB53-21.50M
		13.5	0.531	13.4	0.526	Ø0.75in	AF53-13.50	
		14.0	0.551	13.9	0.546	Ø20mm	AF53-14.00M	
		14.0	0.551	13.9	0.546	Ø0.75in	AF53-14.00	
		14.5	0.571	14.4	0.566	Ø20mm	AF56-14.50M	CB56-21.50M
		14.5	0.571	14.4	0.566	Ø0.75in	AF56-14.50	
22.0	0.866	11.5	0.453	11.4	0.448	Ø20mm	AF44-11.50M	CB44-22.00M
		11.5	0.453	11.4	0.448	Ø0.75in	AF44-11.50	
		12.0	0.472	11.9	0.467	Ø20mm	AF47-12.00M	CB47-22.00M
		12.0	0.472	11.9	0.467	Ø0.75in	AF47-12.00	
		12.5	0.492	12.4	0.487	Ø20mm	AF50-12.50M	CB50-22.00M
		12.5	0.492	12.4	0.487	Ø0.75in	AF50-12.50	
		13.0	0.512	12.9	0.507	Ø20mm	AF50-13.00M	
		13.0	0.512	12.9	0.507	Ø0.75in	AF50-13.00	
		13.5	0.531	13.4	0.526	Ø20mm	AF53-13.50M	CB53-22.00M
		13.5	0.531	13.4	0.526	Ø0.75in	AF53-13.50	
		14.0	0.551	13.9	0.546	Ø20mm	AF53-14.00M	
		14.0	0.551	13.9	0.546	Ø0.75in	AF53-14.00	
		14.5	0.571	14.4	0.566	Ø20mm	AF56-14.50M	CB56-22.00M
		14.5	0.571	14.4	0.566	Ø0.75in	AF56-14.50	
15.0	0.591	14.9	0.585	Ø20mm	AF59-15.00M	CB59-22.00M		
15.0	0.591	14.9	0.585	Ø0.75in	AF59-15.00			
15.5	0.610	15.4	0.605	Ø20mm	AF59-15.50M			
15.5	0.610	15.4	0.605	Ø0.75in	AF59-15.50			

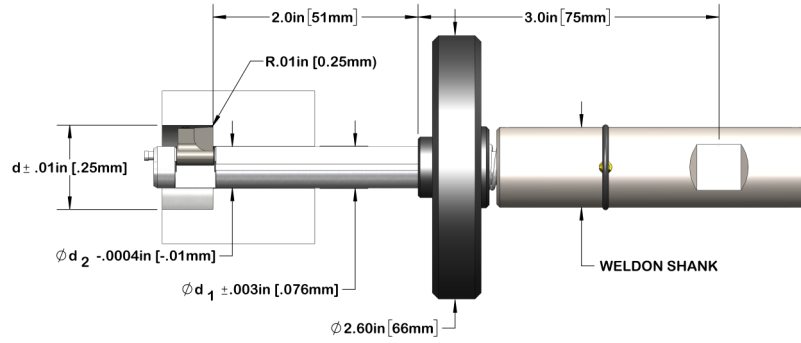

Counterbore		Pilot Hole		Autofacer		Order Number		
d (mm)	d (in)	d ₁ (mm)	d ₁ (in)	d ₂ (mm)	d ₂ (in)	Weldon Shank	Autofacer P/N	Cutter Blade P/N
22.5	0.886	11.5	0.453	11.4	0.448	Ø20mm	AF44-11.50M	CB44-22.50M
		11.5	0.453	11.4	0.448	Ø0.75in	AF44-11.50	
		12.0	0.472	11.9	0.467	Ø20mm	AF47-12.00M	CB47-22.50M
		12.0	0.472	11.9	0.467	Ø0.75in	AF47-12.00	
		12.5	0.492	12.4	0.487	Ø20mm	AF50-12.50M	CB50-22.50M
		12.5	0.492	12.4	0.487	Ø0.75in	AF50-12.50	
		13.0	0.512	12.9	0.507	Ø20mm	AF50-13.00M	
		13.0	0.512	12.9	0.507	Ø0.75in	AF50-13.00	
		13.5	0.531	13.4	0.526	Ø20mm	AF53-13.50M	CB53-22.50M
		13.5	0.531	13.4	0.526	Ø0.75in	AF53-13.50	
		14.0	0.551	13.9	0.546	Ø20mm	AF53-14.00M	CB56-22.50M
		14.0	0.551	13.9	0.546	Ø0.75in	AF53-14.00	
		14.5	0.571	14.4	0.566	Ø20mm	AF56-14.50M	CB59-22.50M
		14.5	0.571	14.4	0.566	Ø0.75in	AF56-14.50	
		15.0	0.591	14.9	0.585	Ø20mm	AF59-15.00M	CB59-22.50M
		15.0	0.591	14.9	0.585	Ø0.75in	AF59-15.00	
15.5	0.610	15.4	0.605	Ø20mm	AF59-15.50M			
15.5	0.610	15.4	0.605	Ø0.75in	AF59-15.50			
23.0	0.906	11.5	0.453	11.4	0.448	Ø20mm	AF44-11.50M	CB44-23.00M
		11.5	0.453	11.4	0.448	Ø0.75in	AF44-11.50	
		12.0	0.472	11.9	0.467	Ø20mm	AF47-12.00M	CB47-23.00M
		12.0	0.472	11.9	0.467	Ø0.75in	AF47-12.00	
		12.5	0.492	12.4	0.487	Ø20mm	AF50-12.50M	CB50-23.00M
		12.5	0.492	12.4	0.487	Ø0.75in	AF50-12.50	
		13.0	0.512	12.9	0.507	Ø20mm	AF50-13.00M	
		13.0	0.512	12.9	0.507	Ø0.75in	AF50-13.00	
		13.5	0.531	13.4	0.526	Ø20mm	AF53-13.50M	CB53-23.00M
		13.5	0.531	13.4	0.526	Ø0.75in	AF53-13.50	
		14.0	0.551	13.9	0.546	Ø20mm	AF53-14.00M	CB56-23.00M
		14.0	0.551	13.9	0.546	Ø0.75in	AF53-14.00	
		14.5	0.571	14.4	0.566	Ø20mm	AF56-14.50M	CB59-23.00M
		14.5	0.571	14.4	0.566	Ø0.75in	AF56-14.50	
		15.0	0.591	14.9	0.585	Ø20mm	AF59-15.00M	CB59-23.00M
		15.0	0.591	14.9	0.585	Ø0.75in	AF59-15.00	
15.5	0.610	15.4	0.605	Ø20mm	AF59-15.50M			
15.5	0.610	15.4	0.605	Ø0.75in	AF59-15.50			

Counterbore		Pilot Hole		Autofacer		Order Number		
d (mm)	d (in)	d ₁ (mm)	d ₁ (in)	d ₂ (mm)	d ₂ (in)	Weldon Shank	Autofacer P/N	Cutter Blade P/N
23.5	0.925	11.5	0.453	11.4	0.448	Ø20mm	AF44-11.50M	CB44-23.50M
		11.5	0.453	11.4	0.448	Ø0.75in	AF44-11.50	
		12.0	0.472	11.9	0.467	Ø20mm	AF47-12.00M	CB47-23.50M
		12.0	0.472	11.9	0.467	Ø0.75in	AF47-12.00	
		12.5	0.492	12.4	0.487	Ø20mm	AF50-12.50M	CB50-23.50M
		12.5	0.492	12.4	0.487	Ø0.75in	AF50-12.50	
		13.0	0.512	12.9	0.507	Ø20mm	AF50-13.00M	
		13.0	0.512	12.9	0.507	Ø0.75in	AF50-13.00	
		13.5	0.531	13.4	0.526	Ø20mm	AF53-13.50M	CB53-23.50M
		13.5	0.531	13.4	0.526	Ø0.75in	AF53-13.50	
		14.0	0.551	13.9	0.546	Ø20mm	AF53-14.00M	CB56-23.50M
		14.0	0.551	13.9	0.546	Ø0.75in	AF53-14.00	
		14.5	0.571	14.4	0.566	Ø20mm	AF56-14.50M	CB59-23.50M
		14.5	0.571	14.4	0.566	Ø0.75in	AF56-14.50	
		15.0	0.591	14.9	0.585	Ø20mm	AF59-15.00M	CB59-23.50M
		15.0	0.591	14.9	0.585	Ø0.75in	AF59-15.00	
15.5	0.610	15.4	0.605	Ø20mm	AF59-15.50M			
15.5	0.610	15.4	0.605	Ø0.75in	AF59-15.50			
24.0	0.945	12.0	0.472	11.9	0.467	Ø20mm	AF47-12.00M	CB47-24.00M
		12.0	0.472	11.9	0.467	Ø0.75in	AF47-12.00	
		12.5	0.492	12.4	0.487	Ø20mm	AF50-12.50M	CB50-24.00M
		12.5	0.492	12.4	0.487	Ø0.75in	AF50-12.50	
		13.0	0.512	12.9	0.507	Ø20mm	AF50-13.00M	CB53-24.00M
		13.0	0.512	12.9	0.507	Ø0.75in	AF50-13.00	
		13.5	0.531	13.4	0.526	Ø20mm	AF53-13.50M	
		13.5	0.531	13.4	0.526	Ø0.75in	AF53-13.50	
		14.0	0.551	13.9	0.546	Ø20mm	AF53-14.00M	CB56-24.00M
		14.0	0.551	13.9	0.546	Ø0.75in	AF53-14.00	
		14.5	0.571	14.4	0.566	Ø20mm	AF56-14.50M	CB59-24.00M
		14.5	0.571	14.4	0.566	Ø0.75in	AF56-14.50	
		15.0	0.591	14.9	0.585	Ø20mm	AF59-15.00M	CB59-24.00M
		15.0	0.591	14.9	0.585	Ø0.75in	AF59-15.00	
		15.5	0.610	15.4	0.605	Ø20mm	AF59-15.50M	
		15.5	0.610	15.4	0.605	Ø0.75in	AF59-15.50	
24.5	0.965	12.0	0.472	11.9	0.467	Ø20mm	AF47-12.00M	CB47-24.50M
		12.0	0.472	11.9	0.467	Ø0.75in	AF47-12.00	
		12.5	0.492	12.4	0.487	Ø20mm	AF50-12.50M	CB50-24.50M
		12.5	0.492	12.4	0.487	Ø0.75in	AF50-12.50	
		13.0	0.512	12.9	0.507	Ø20mm	AF50-13.00M	CB53-24.50M
		13.0	0.512	12.9	0.507	Ø0.75in	AF50-13.00	
		13.5	0.531	13.4	0.526	Ø20mm	AF53-13.50M	
		13.5	0.531	13.4	0.526	Ø0.75in	AF53-13.50	
		14.0	0.551	13.9	0.546	Ø20mm	AF53-14.00M	CB56-24.50M
		14.0	0.551	13.9	0.546	Ø0.75in	AF53-14.00	
		14.5	0.571	14.4	0.566	Ø20mm	AF56-14.50M	CB59-24.50M
		14.5	0.571	14.4	0.566	Ø0.75in	AF56-14.50	
		15.0	0.591	14.9	0.585	Ø20mm	AF59-15.00M	CB59-24.50M
		15.0	0.591	14.9	0.585	Ø0.75in	AF59-15.00	
		15.5	0.610	15.4	0.605	Ø20mm	AF59-15.50M	
		15.5	0.610	15.4	0.605	Ø0.75in	AF59-15.50	

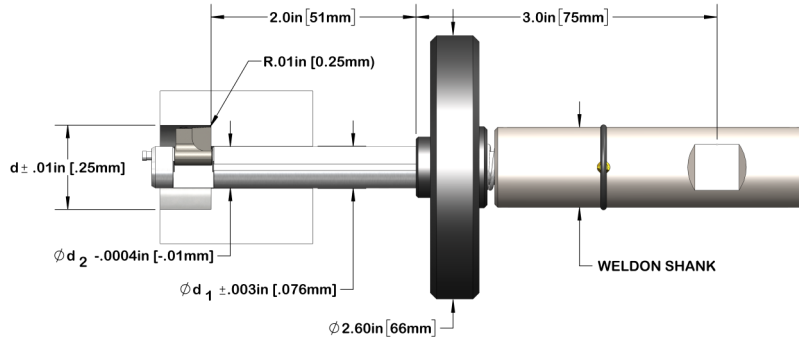

Counterbore		Pilot Hole		Autofacer		Order Number		
d (mm)	d (in)	d ₁ (mm)	d ₁ (in)	d ₂ (mm)	d ₂ (in)	Weldon Shank	Autofacer P/N	Cutter Blade P/N
25.0	0.984	12.0	0.472	11.9	0.467	Ø20mm	AF47-12.00M	CB47-25.00M
		12.0	0.472	11.9	0.467	Ø0.75in	AF47-12.00	
		12.5	0.492	12.4	0.487	Ø20mm	AF50-12.50M	CB50-25.00M
		12.5	0.492	12.4	0.487	Ø0.75in	AF50-12.50	
		13.0	0.512	12.9	0.507	Ø20mm	AF50-13.00M	CB50-25.00M
		13.0	0.512	12.9	0.507	Ø0.75in	AF50-13.00	
		13.5	0.531	13.4	0.526	Ø20mm	AF53-13.50M	CB53-25.00M
		13.5	0.531	13.4	0.526	Ø0.75in	AF53-13.50	
		14.0	0.551	13.9	0.546	Ø20mm	AF53-14.00M	CB53-25.00M
		14.0	0.551	13.9	0.546	Ø0.75in	AF53-14.00	
		14.5	0.571	14.4	0.566	Ø20mm	AF56-14.50M	CB56-25.00M
		14.5	0.571	14.4	0.566	Ø0.75in	AF56-14.50	
		15.0	0.591	14.9	0.585	Ø20mm	AF59-15.00M	CB59-25.00M
		15.0	0.591	14.9	0.585	Ø0.75in	AF59-15.00	
		15.5	0.610	15.4	0.605	Ø20mm	AF59-15.50M	CB59-25.00M
		15.5	0.610	15.4	0.605	Ø0.75in	AF59-15.50	
25.5	1.004	12.0	0.472	11.9	0.467	Ø20mm	AF47-12.00M	CB47-25.50M
		12.0	0.472	11.9	0.467	Ø0.75in	AF47-12.00	
		12.5	0.492	12.4	0.487	Ø20mm	AF50-12.50M	CB50-25.50M
		12.5	0.492	12.4	0.487	Ø0.75in	AF50-12.50	
		13.0	0.512	12.9	0.507	Ø20mm	AF50-13.00M	CB50-25.50M
		13.0	0.512	12.9	0.507	Ø0.75in	AF50-13.00	
		13.5	0.531	13.4	0.526	Ø20mm	AF53-13.50M	CB53-25.50M
		13.5	0.531	13.4	0.526	Ø0.75in	AF53-13.50	
		14.0	0.551	13.9	0.546	Ø20mm	AF53-14.00M	CB53-25.50M
		14.0	0.551	13.9	0.546	Ø0.75in	AF53-14.00	
		14.5	0.571	14.4	0.566	Ø20mm	AF56-14.50M	CB56-25.50M
		14.5	0.571	14.4	0.566	Ø0.75in	AF56-14.50	
		15.0	0.591	14.9	0.585	Ø20mm	AF59-15.00M	CB59-25.50M
		15.0	0.591	14.9	0.585	Ø0.75in	AF59-15.00	
		15.5	0.610	15.4	0.605	Ø20mm	AF59-15.50M	CB59-25.50M
		15.5	0.610	15.4	0.605	Ø0.75in	AF59-15.50	
26.0	1.024	12.5	0.492	12.4	0.487	Ø20mm	AF50-12.50M	CB50-26.00M
		12.5	0.492	12.4	0.487	Ø0.75in	AF50-12.50	
		13.0	0.512	12.9	0.507	Ø20mm	AF50-13.00M	CB50-26.00M
		13.0	0.512	12.9	0.507	Ø0.75in	AF50-13.00	
		13.5	0.531	13.4	0.526	Ø20mm	AF53-13.50M	CB53-26.00M
		13.5	0.531	13.4	0.526	Ø0.75in	AF53-13.50	
		14.0	0.551	13.9	0.546	Ø20mm	AF53-14.00M	CB53-26.00M
		14.0	0.551	13.9	0.546	Ø0.75in	AF53-14.00	
		14.5	0.571	14.4	0.566	Ø20mm	AF56-14.50M	CB56-26.00M
		14.5	0.571	14.4	0.566	Ø0.75in	AF56-14.50	
		15.0	0.591	14.9	0.585	Ø20mm	AF59-15.00M	CB59-26.00M
		15.0	0.591	14.9	0.585	Ø0.75in	AF59-15.00	
		15.5	0.610	15.4	0.605	Ø20mm	AF59-15.50M	CB59-26.00M
		15.5	0.610	15.4	0.605	Ø0.75in	AF59-15.50	

Counterbore		Pilot Hole		Autofacer		Order Number				
d (mm)	d (in)	d ₁ (mm)	d ₁ (in)	d ₂ (mm)	d ₂ (in)	Weldon Shank	Autofacer P/N	Cutter Blade P/N		
26.5	1.043	12.5	0.492	12.4	0.487	Ø20mm	AF50-12.50M	CB50-26.50M		
		12.5	0.492	12.4	0.487	Ø0.75in	AF50-12.50			
		13.0	0.512	12.9	0.507	Ø20mm	AF50-13.00M	CB50-26.50M		
		13.0	0.512	12.9	0.507	Ø0.75in	AF50-13.00			
		13.5	0.531	13.4	0.526	Ø20mm	AF53-13.50M	CB53-26.50M		
		13.5	0.531	13.4	0.526	Ø0.75in	AF53-13.50			
		14.0	0.551	13.9	0.546	Ø20mm	AF53-14.00M	CB53-26.50M		
		14.0	0.551	13.9	0.546	Ø0.75in	AF53-14.00			
		14.5	0.571	14.4	0.566	Ø20mm	AF56-14.50M	CB56-26.50M		
		14.5	0.571	14.4	0.566	Ø0.75in	AF56-14.50			
		15.0	0.591	14.9	0.585	Ø20mm	AF59-15.00M	CB59-26.50M		
		15.0	0.591	14.9	0.585	Ø0.75in	AF59-15.00			
		15.5	0.610	15.4	0.605	Ø20mm	AF59-15.50M	CB59-26.50M		
		15.5	0.610	15.4	0.605	Ø0.75in	AF59-15.50			
		27.0	1.063	12.5	0.492	12.4	0.487	Ø20mm	AF50-12.50M	CB50-27.00M
				12.5	0.492	12.4	0.487	Ø0.75in	AF50-12.50	
13.0	0.512			12.9	0.507	Ø20mm	AF50-13.00M	CB50-27.00M		
13.0	0.512			12.9	0.507	Ø0.75in	AF50-13.00			
13.5	0.531			13.4	0.526	Ø20mm	AF53-13.50M	CB53-27.00M		
13.5	0.531			13.4	0.526	Ø0.75in	AF53-13.50			
14.0	0.551			13.9	0.546	Ø20mm	AF53-14.00M	CB53-27.00M		
14.0	0.551			13.9	0.546	Ø0.75in	AF53-14.00			
14.5	0.571			14.4	0.566	Ø20mm	AF56-14.50M	CB56-27.00M		
14.5	0.571			14.4	0.566	Ø0.75in	AF56-14.50			
15.0	0.591			14.9	0.585	Ø20mm	AF59-15.00M	CB59-27.00M		
15.0	0.591			14.9	0.585	Ø0.75in	AF59-15.00			
15.5	0.610			15.4	0.605	Ø20mm	AF59-15.50M	CB59-27.00M		
15.5	0.610			15.4	0.605	Ø0.75in	AF59-15.50			
27.5	1.083			12.5	0.492	12.4	0.487	Ø20mm	AF50-12.50M	CB50-27.50M
				12.5	0.492	12.4	0.487	Ø0.75in	AF50-12.50	
		13.0	0.512	12.9	0.507	Ø20mm	AF50-13.00M	CB50-27.50M		
		13.0	0.512	12.9	0.507	Ø0.75in	AF50-13.00			
		13.5	0.531	13.4	0.526	Ø20mm	AF53-13.50M	CB53-27.50M		
		13.5	0.531	13.4	0.526	Ø0.75in	AF53-13.50			
		14.0	0.551	13.9	0.546	Ø20mm	AF53-14.00M	CB53-27.50M		
		14.0	0.551	13.9	0.546	Ø0.75in	AF53-14.00			
		14.5	0.571	14.4	0.566	Ø20mm	AF56-14.50M	CB56-27.50M		
		14.5	0.571	14.4	0.566	Ø0.75in	AF56-14.50			
		15.0	0.591	14.9	0.585	Ø20mm	AF59-15.00M	CB59-27.50M		
		15.0	0.591	14.9	0.585	Ø0.75in	AF59-15.00			
		15.5	0.610	15.4	0.605	Ø20mm	AF59-15.50M	CB59-27.50M		
		15.5	0.610	15.4	0.605	Ø0.75in	AF59-15.50			

Counterbore Ø | 28mm (1.102in) - 33mm (1.299in)

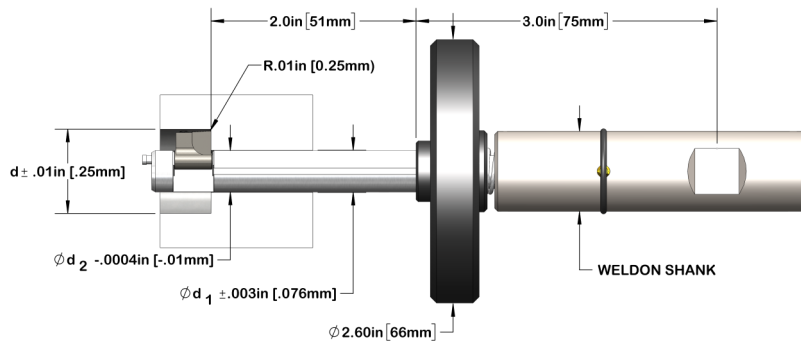

Counterbore		Pilot Hole		Autofacer		Order Number		
d (mm)	d (in)	d₁ (mm)	d₁ (in)	d₂ (mm)	d₂ (in)	Weldon Shank	Autofacer P/N	Cutter Blade P/N
28.0	1.102	12.5	0.492	12.37	0.487	Ø20mm	AF50-12.50M	CB50-28.00M
		12.5	0.492	12.37	0.487	Ø0.75in	AF50-12.50	
		13.0	0.512	12.87	0.507	Ø20mm	AF50-13.00M	
		13.0	0.512	12.87	0.507	Ø0.75in	AF50-13.00	
		13.5	0.531	13.37	0.526	Ø20mm	AF53-13.50M	CB53-28.00M
		13.5	0.531	13.37	0.526	Ø0.75in	AF53-13.50	
		14.0	0.551	13.87	0.546	Ø20mm	AF53-14.00M	CB53-28.00M
		14.0	0.551	13.87	0.546	Ø0.75in	AF53-14.00	
		14.5	0.571	14.37	0.566	Ø20mm	AF56-14.50M	CB56-28.00M
		14.5	0.571	14.37	0.566	Ø0.75in	AF56-14.50	
		15.0	0.591	14.87	0.585	Ø20mm	AF59-15.00M	CB59-28.00M
		15.0	0.591	14.87	0.585	Ø0.75in	AF59-15.00	
		15.5	0.610	15.37	0.605	Ø20mm	AF59-15.50M	CB59-28.00M
		15.5	0.610	15.37	0.605	Ø0.75in	AF59-15.50	
28.5	1.122	13.5	0.531	13.37	0.526	Ø20mm	AF53-13.50M	CB53-28.50M
		13.5	0.531	13.37	0.526	Ø0.75in	AF53-13.50	
		14.0	0.551	13.87	0.546	Ø20mm	AF53-14.00M	CB53-28.50M
		14.0	0.551	13.87	0.546	Ø0.75in	AF53-14.00	
		14.5	0.571	14.37	0.566	Ø20mm	AF56-14.50M	CB56-28.50M
		14.5	0.571	14.37	0.566	Ø0.75in	AF56-14.50	
		15.0	0.591	14.87	0.585	Ø20mm	AF59-15.00M	CB59-28.50M
		15.0	0.591	14.87	0.585	Ø0.75in	AF59-15.00	
		15.5	0.610	15.37	0.605	Ø20mm	AF59-15.50M	CB59-28.50M
		15.5	0.610	15.37	0.605	Ø0.75in	AF59-15.50	
29.0	1.142	13.5	0.531	13.37	0.526	Ø20mm	AF53-13.50M	CB53-29.00M
		13.5	0.531	13.37	0.526	Ø0.75in	AF53-13.50	
		14.0	0.551	13.87	0.546	Ø20mm	AF53-14.00M	CB53-29.00M
		14.0	0.551	13.87	0.546	Ø0.75in	AF53-14.00	
		14.5	0.571	14.37	0.566	Ø20mm	AF56-14.50M	CB56-29.00M
		14.5	0.571	14.37	0.566	Ø0.75in	AF56-14.50	
		15.0	0.591	14.87	0.585	Ø20mm	AF59-15.00M	CB59-29.00M
		15.0	0.591	14.87	0.585	Ø0.75in	AF59-15.00	
		15.5	0.610	15.37	0.605	Ø20mm	AF59-15.50M	CB59-29.00M
		15.5	0.610	15.37	0.605	Ø0.75in	AF59-15.50	
29.5	1.161	14.5	0.571	14.37	0.566	Ø20mm	AF56-14.50M	CB56-29.50M
		14.5	0.571	14.37	0.566	Ø0.75in	AF56-14.50	
		15.0	0.591	14.87	0.585	Ø20mm	AF59-15.00M	CB59-29.50M
		15.0	0.591	14.87	0.585	Ø0.75in	AF59-15.00	
		15.5	0.610	15.37	0.605	Ø20mm	AF59-15.50M	CB59-29.50M
		15.5	0.610	15.37	0.605	Ø0.75in	AF59-15.50	
30.0	1.181	14.5	0.571	14.37	0.566	Ø20mm	AF56-14.50M	CB56-30.00M
		14.5	0.571	14.37	0.566	Ø0.75in	AF56-14.50	
		15.0	0.591	14.87	0.585	Ø20mm	AF59-15.00M	CB59-30.00M
		15.0	0.591	14.87	0.585	Ø0.75in	AF59-15.00	
		15.5	0.610	15.37	0.605	Ø20mm	AF59-15.50M	CB59-30.00M
		15.5	0.610	15.37	0.605	Ø0.75in	AF59-15.50	

Counterbore		Pilot Hole		Autofacer		Order Number		
d (mm)	d (in)	d₁ (mm)	d₁ (in)	d₂ (mm)	d₂ (in)	Weldon Shank	Autofacer P/N	Cutter Blade P/N
30.5	1.201	14.5	0.571	14.37	0.566	Ø20mm	AF56-14.50M	CB56-30.50M
		14.5	0.571	14.37	0.566	Ø0.75in	AF56-14.50	
		15.0	0.591	14.87	0.585	Ø20mm	AF59-15.00M	CB59-30.50M
		15.0	0.591	14.87	0.585	Ø0.75in	AF59-15.00	
		15.5	0.610	15.37	0.605	Ø20mm	AF59-15.50M	
		15.5	0.610	15.37	0.605	Ø0.75in	AF59-15.50	
31.0	1.220	14.5	0.571	14.37	0.566	Ø20mm	AF56-14.50M	CB56-31.00M
		14.5	0.571	14.37	0.566	Ø0.75in	AF56-14.50	
		15.0	0.591	14.87	0.585	Ø20mm	AF59-15.00M	CB59-31.00M
		15.0	0.591	14.87	0.585	Ø0.75in	AF59-15.00	
		15.5	0.610	15.37	0.605	Ø20mm	AF59-15.50M	
		15.5	0.610	15.37	0.605	Ø0.75in	AF59-15.50	
31.5	1.240	14.5	0.571	14.37	0.566	Ø20mm	AF56-14.50M	CB56-31.50M
		14.5	0.571	14.37	0.566	Ø0.75in	AF56-14.50	
		15.0	0.591	14.87	0.585	Ø20mm	AF59-15.00M	CB59-31.50M
		15.0	0.591	14.87	0.585	Ø0.75in	AF59-15.00	
		15.5	0.610	15.37	0.605	Ø20mm	AF59-15.50M	
		15.5	0.610	15.37	0.605	Ø0.75in	AF59-15.50	
32.0	1.260	14.5	0.571	14.37	0.566	Ø20mm	AF56-14.50M	CB56-32.00M
		14.5	0.571	14.37	0.566	Ø0.75in	AF56-14.50	
		15.0	0.591	14.87	0.585	Ø20mm	AF59-15.00M	CB59-32.00M
		15.0	0.591	14.87	0.585	Ø0.75in	AF59-15.00	
		15.5	0.610	15.37	0.605	Ø20mm	AF59-15.50M	
		15.5	0.610	15.37	0.605	Ø0.75in	AF59-15.50	
32.5	1.280	15.0	0.591	14.87	0.585	Ø20mm	AF59-15.00M	CB59-32.50M
		15.0	0.591	14.87	0.585	Ø0.75in	AF59-15.00	
		15.5	0.610	15.37	0.605	Ø20mm	AF59-15.50M	CB59-32.50M
		15.5	0.610	15.37	0.605	Ø0.75in	AF59-15.50	
33.0	1.299	15.0	0.591	14.87	0.585	Ø20mm	AF59-15.00M	CB59-33.00M
		15.0	0.591	14.87	0.585	Ø0.75in	AF59-15.00	
		15.5	0.610	15.37	0.605	Ø20mm	AF59-15.50M	CB59-33.00M
		15.5	0.610	15.37	0.605	Ø0.75in	AF59-15.50	

