

KATO



ΑΔΥΛΠΕΧ

DISTRIBUTORE:
TECNIMETAL

Via degli Andreani, 9 - 40037 Sasso Marconi (BO) - Tel: 051 735744
E-mail: info@tecnimetal-tm.com - www.tecnimetal-tm.com

KATO CoilThread[®] Tangless Inserts

Tangless threaded inserts

*Tangless[®] threaded inserts without a tang driver by Advanex Inc. The ORIGINAL Tangless[®] products are manufactured by KATO - Advanex
Compliant with AS7245, NASM8846-33537-122076-124651-21209, NAS1130, AS5272, ASME B18.29.1, NA0276, MA3279-3329-1565-1567, RoHs, DFARS,*





ΑΔΥΛΠΕΧ

Advantex Group

Precision Metal

Components

Over 20 plants around the world

(Asia, Europe, America)

Areas of application:

Computers

Medical/Pharmaceutical

Automotive/Motorsport

Aerospace/Satellites

Telecommunications

Defense/Security

Agriculture

Irrigation

Renewable energies

Technology for the environment

Toys

Environment

Office equipment

Home appliances

Construction/Building

Food/Beverage

Railway Industry

Health/Safety



Precision compression springs, extension springs, torsion springs, micro springs, flat springs, Tangless and driver-threaded inserts, LockOne, compression limiters, stamped parts with a diameter-to-length ratio up to 1:40, constant torque hinges, and other precision components.



TECHNOLOGY THAT SIMPLIFIES THREADED INSERT USAGE AND MAKES IT SAFER
Introducing Tangless, KATO - Advanex has revolutionized the threaded insert market.

COMPLIANCE

Tangless inserts comply with aerospace and military standards NASM8846-33537-122076-124651-21209, NAS1130, AS5272, ASME B18.29.1, NA0276, MA3379-3329-1565-1567, etc. and to the directives RoHS e DFARS. Designed to meet the high standards of quality and safety in the military and aerospace sectors, their use has since expanded to encompass all industrial applications.



NO TANG DRIVER TO BE BROKEN, RETRIEVED, OR LOST

The risk of short circuits, jams, or malfunctions caused by unretrieved tangs circulating during equipment operation is eliminated.

SOME ISSUES WITH TRADITIONAL THREADED INSERTS WITH DRIVING TANGS



Tangless
 =
 FOD Free
 (Foreign Object Debris)

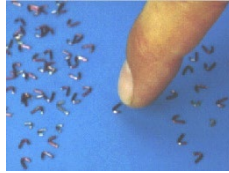

Broken tangs persist at the work site.



Difficulty in retrieving tangs from blind holes.

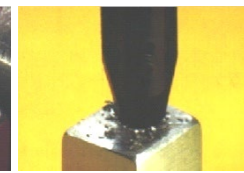

Extraction, when necessary, can cause damage.

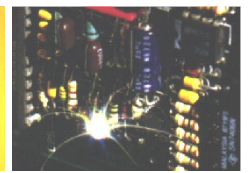

Unrecovered tangs can cause issues (e.g., short circuits).

TIME SAVING - INSTALLATION COSTS REDUCTION

No tang driver to break. No time wasted on its retrieval. Eliminates the inconvenience of coil jump often caused by tang breakage with a punch. Bi-directional, having engagement on both sides, eliminating the need for orientation during installation.

HIGH QUALITY = NULLIFICATION OR MINIMIZATION OF REJECTION AND REPAIR TIME



QUICK AND NON-DESTRUCTIVE REMOVAL AND/OR REPLACEMENT
NO DAMAGE - MINIMIZATION OF DOWNTIME

If removal is necessary, it reduces to a simple unscrewing operation and is non-destructive. Easy replacement is possible in case of wear or for the self-locking model in the event of a decrease in braking values due to numerous unscrewing operations or the use of the "screw - self-locking threaded insert" joint as trim.

OTHER ADVANTAGES

They can be easily stacked to achieve non-standard lengths or with multiple self-locking features to achieve a very high braking torque.

COMMON APPLICATION AREAS

AEROSPACE: Fuel injection systems, Fuel pumps, Alternators, Missiles, Rotary actuators, Housings, Galleys, Braking systems, Aircraft seats, etc.

ELECTRONICS: Computers for harsh environments, Portable radios, Military racks for control electronics, Various containers, Mobile phone transmitters, Heatsinks, Electric motors and alternators, etc.

AUTOMOTIVE: Transmission cases, Engines, Dashboards, Locomotive cabs, Steering components, Oil filters, etc.

OTHER: Cameras, Vending machines, Medical equipment and tools, Automated machinery, etc.

KATO is utilized in the production programs of leading companies in the manufacturing of aircraft, electronic devices, and mechanical components for the aerospace, military, automotive, missile, F1 racing cars, heavy-duty vehicles, etc.



FEATURES

SAME threading and hole preparation as traditional inserts with a tang driver.
SAME functionality as traditional inserts, they are COMPATIBLE & REPLACEABLE

Tangless threaded inserts without a tang driver are available as standard in AISI304 stainless steel (AS7245, 18-10 stainless steel), cold-rolled to achieve a tensile strength of 1400 N/mm² (200,000 psi) and a surface hardness of 43-50 HRc. Cold rolling allows for a superior quality thread with a very high surface finish, extending the life of the assembly by reducing thread wear due to friction and the effects of galvanic corrosion. Standard Tangless inserts in AISI304 are suitable for use in temperatures ranging from -195.6°C to +426.7°C (-320°F to +800°F). They are also available with Dry-Lube, Cadmium, or Silver plating. Once installed, they form a 4H-5H or 2B-3B class thread capable of accommodating M, MJ, UN, UNJ screws. Available in Metric, UNC, UNF sizes, in Free Running or Locking versions, and in Coils for automated applications.

OPERATING PRINCIPLE OF INSTALLATION EQUIPMENT

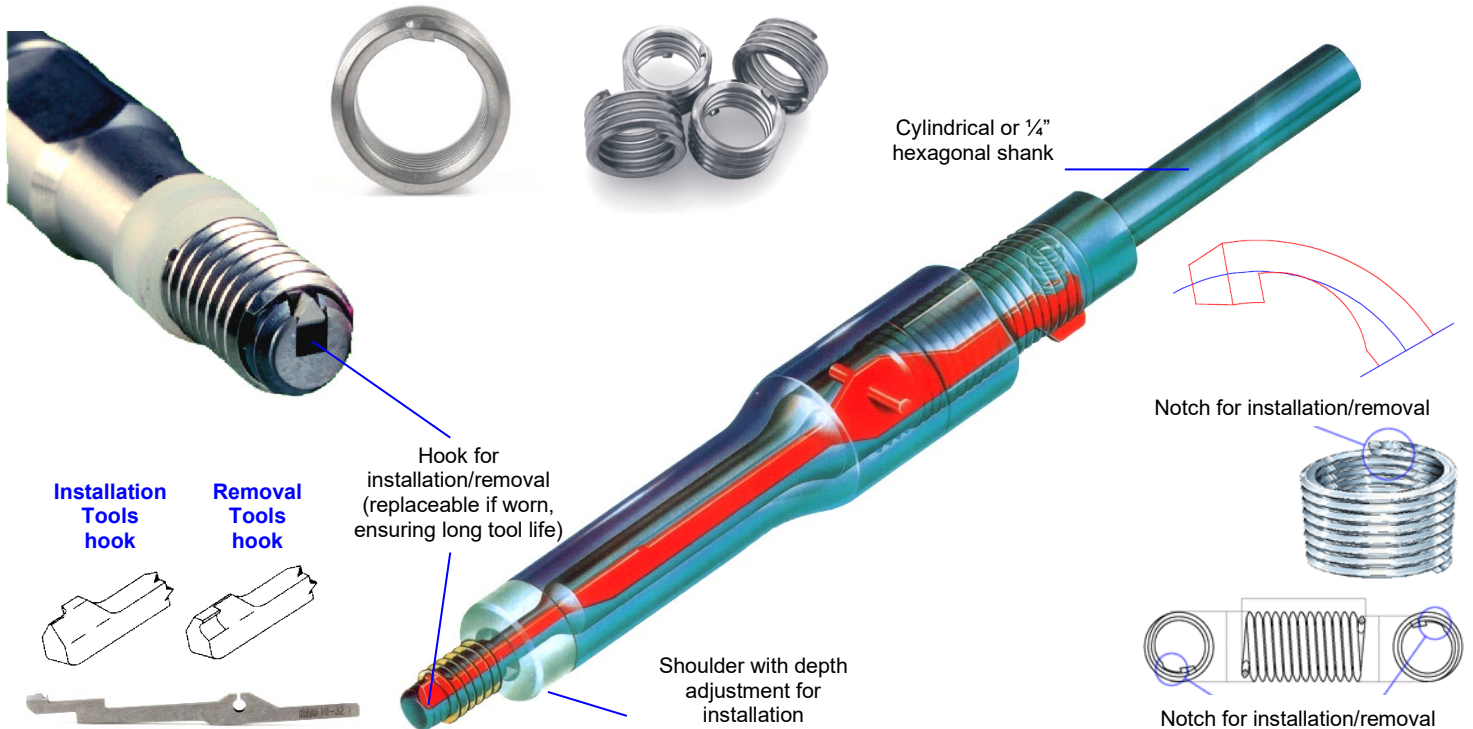

INSTALLATION

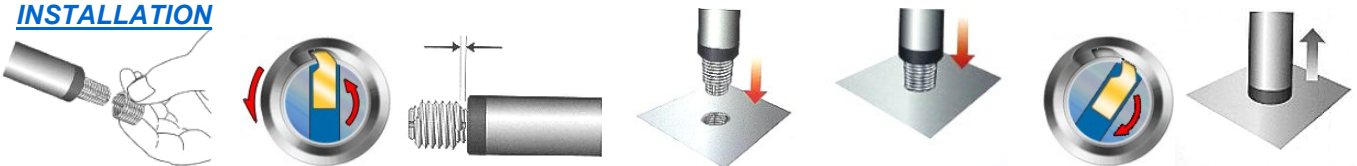

REMOVAL

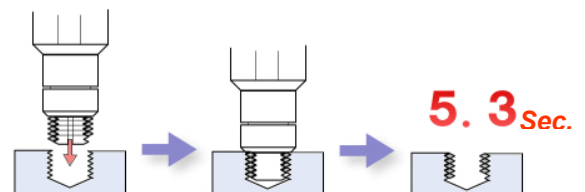
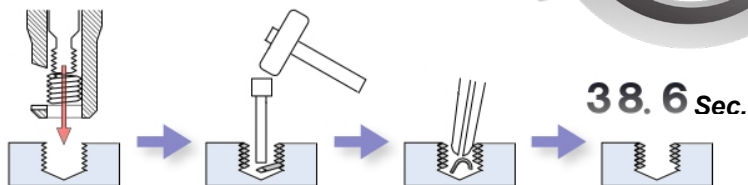
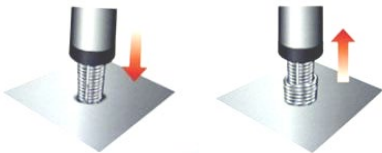

Installation of traditional threaded inserts with a tang driver

Tangless Installation

MATERIALS



AISI304 (Inox 18-10) **Standard material**

It meets most of the required characteristics for tensile strength, corrosion resistance, and operating temperature. Following the cold-rolling process, the material becomes slightly magnetic.

Operating Temperature: -195,6°C a +426,7°C
(-320°F - +800°F)

Tensile strength: 1400N/mm² (200.000 psi)

Hardness: 43-50 Hrc

Magnetic Permeability: 2-10 G/O

Material specification: AS7245, NASM8846 and alloy UNS S30400



INCONEL X-750

Available upon request

Used in applications where strength and reliability are required with high operating temperatures. It has the same tensile strength and hardness as AISI304, with low magnetic permeability.

Max operating temperature: +537°C (+1000°F)

Tensile strength: 1400N/mm² (200.000 psi)

Hardness: 43-50 Hrc

Magnetic Permeability: <1.0 G/O

Material specification: AS7246

Typical applications: gas turbines, rocket engines, nuclear reactors, high-pressure tanks, various aerospace components subjected to high temperatures.



PHOSPHORUS BRONZE

Available upon request

Ideal for marine applications, it has superior corrosion resistance to AISI304 and Inconel X-750, although it does not have the same tensile strength characteristics. Phosphorus bronze is also used in applications where low magnetic permeability (<1.0 G/O) is required.

Max operating temperature: +300°C (+572°F)

Tensile strength: 965N/mm² (140.000 psi)

Hardness: 95 HRB

Material specification: AMS7247

Typical applications: naval applications, aeronautical instrumentation, paper and textile manufacturing, automotive systems, mining and drilling industry, pumps and valves, electrical connectors.



NITRONIC 60®

Available upon request

Designed to eliminate seizing and subsequent wear resulting from the use of stainless steel screws on stainless steel inserts. Inserts made of this material do not require anti-seize treatments or surface coatings, making them ideal for use under vacuum conditions as there is no "outgassing." Additionally, they do not have the temperature limitations associated with surface treatments, such as cadmium or dry-lube.

Max operating temperature: +260°C (+500°F)

Tensile strength: 1400N/mm² (200.000 psi)

Hardness: 43-50 Hrc

Magnetic permeability: <1 G/O

Material specification: UNS S21800

(Nitronic 60® is a registered trademark of AK Steel)

Typical applications: aerospace and semiconductor industry.



NIMONIC 90®

Available upon request

Used in applications with extreme temperatures and pressures. Ideal applications include aircraft engines and gas turbines.

Max operating temperature:

+648°C FR inserts / 482°C Locking inserts

+1200°F FR inserts / 900°F Locking inserts

Tensile strength: 1400N/mm² (200.000 psi)

Material specification: British Standard BS HR 503

(Nimonic 90® is a registered trademark Special Metals Co.)

Typical applications: aircraft parts, gas turbine components, jet engines, exhaust nozzles.

COATINGS



DRY-LUBE

Dry-lubricated, treatment to reduce friction and screw seizing.

Max operating temperature: 315°C – 600°F.

Appearance: gray, dark gray

Specifications: AS5272, MIL-L-46010



SILVER PLATING

Silver-plated, treatment for high-temperature applications that reduces the phenomenon of screw seizing.

Max operating temperature: 650°C – 1200°F.

Appearance: light silver, white

Specification: QQ-S-365



CADMIUM

Cadmium-plated, treatment for military applications, corrosion-resistant and lubricating, not recommended for new applications due to its toxicity.

Max operating temperature: 650°C – 1200°F.

Appearance: Free Running inserts in gold, Locking inserts in shades of dark gray/olive green or dark brown.

Specification: ASM-QQ-P-416 Type II



COLORING

Coloring for identification purposes: green, blue

Standard coloring: all Locking inserts are colored red as a standard in accordance with NAS1130, NA0276, NASM21209.

Other treatments: Electroless Nickel, passivation, etc.

LOCKING INSERTS

Tangless inserts are available in standard (FR – Free Running) and self-locking (SL – Screw Locking) versions. The self-locking version applies a braking torque to the screw thread, preventing loosening due to vibrations or impacts. Self-locking threaded inserts eliminate the need for additional bulky locking systems. They are excellent in applications where adjustment screws are required, preventing the screw from moving from its position.

How do self-locking threaded inserts work?

A common misconception when discussing Locking threaded inserts is that the insert anchors itself to its seat. Both the Free and Locking versions anchor by compression to the installation seat; the Locking version additionally applies a braking torque to the screw. Locking threaded inserts have one or more polygonal coils that, as the screw thread passes through, flex and exert pressure on the flanks of the threading, thereby maximizing the contact area.

Position of the locking polygonal coils

For lengths 1d, 1.5d, and 2d, the center of the locking coil or coils is equal to $\frac{1}{2}$ the number of standard coils. For lengths 2.5d and 3d, the locking coil for inserts with a tang driver is positioned at the same distance from the tang as the 2d inserts, and for Tangless inserts without a tang driver, it is equal to $\frac{1}{2}$ the number of standard coils.

Braking torque

KATO Advanex Locking inserts have braking torques in accordance with NASM8846 (UNC-UNF sizes) and MA1565 (metric sizes) that require the maintenance of specific braking values.

NASM8846 specifies that housing threads should be in 2024-T4 aluminum blocks with 3B class threads in accordance with NASM33537. MA1565 specifies that housing threads should be in 2024-T4 aluminum blocks with 4H class threads in accordance with MA1567. The screws used are 36-42Hrc with Cadmium plating.

To achieve maximum performance in terms of locking torque, it is recommended to use H4 or 3B taps to thread the insert housing and to check the threads with a go/no-go gauge.

Locking threaded inserts are colored in red for identification according to international standards. The coloring is achieved using dyes that do not alter tolerances and can be easily removed by washing with solvents or alcohol.

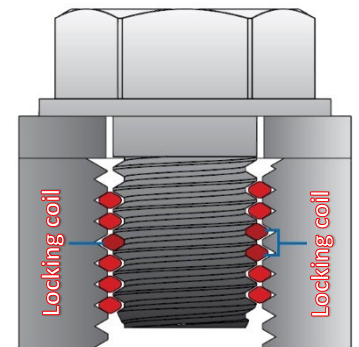
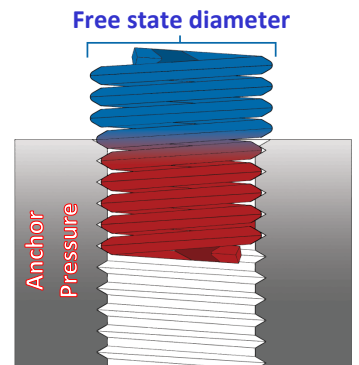

Polygonal Locking Coil

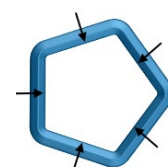
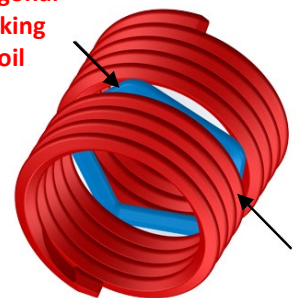

Braking pressure on the screw flank

LOCKING THREADS BRAKING TORQUE

Thread size	Max Breaking Torque	Min Unscrewing Torque	Thread size	Max Breaking Torque	Min Unscrewing Torque
Metric - Coarse thread			UNC – Coarse thread		
M2X0.4	0.12 Nm	0.003 Nm	1 (.073)-64	15 ozf-in	2 ozf-in
M2.2X0.45	0.14 Nm	0.02 Nm	2 (.086)-56	20 ozf-in	3 ozf-in
M2.5X0.45	0.22 Nm	0.06 Nm	3 (.099)-48	32 ozf-in	7 ozf-in
M3X0.5	0.44 Nm	0.1 Nm	4 (.112)-40	48 ozf-in	10 ozf-in
M3.5X0.6	0.68 Nm	0.12 Nm	5 (.125)-40	75 ozf-in	13 ozf-in
M4X0.7	0.9 Nm	0.16 Nm	6 (.138)-32	6 lbf-in	1 lbf-in
M5X0.8	1.6 Nm	0.3 Nm	8 (.164)-32	9 lbf-in	1.5 lbf-in
M6X1	3 Nm	0.4 Nm	10 (.190)-24	13 lbf-in	2 lbf-in
M7X1	4.4 Nm	0.6 Nm	12 (.216)-24 ¹	24 lbf-in	3 lbf-in
M8X1.25	6 Nm	0.8 Nm	1/4 (.250)-20	30 lbf-in	4.5 lbf-in
M10X1.5	10 Nm	1.4 Nm	5/16 (.3125)-18	60 lbf-in	7.5 lbf-in
M12X1.75	15 Nm	2.2 Nm	3/8 (.3750)-16	80 lbf-in	12 lbf-in
M14X2	23 Nm	3 Nm	7/16 (.4375)-14	100 lbf-in	16.5 lbf-in
M16X2	32 Nm	4.2 Nm	1/2 (.5000)-13	150 lbf-in	24 lbf-in
M18X2.5	42 Nm	5.5 Nm	9/16 (.5625)-12	200 lbf-in	30 lbf-in
M20X2.5	54 Nm	7 Nm	5/8 (.6250)-11	300 lbf-in	40 lbf-in
M22X2.5	70 Nm	9 Nm	3/4 (.7500)-10	400 lbf-in	60 lbf-in
M24X3	80 Nm	11 Nm	7/8 (.8750)-9	600 lbf-in	82 lbf-in
M27X3	95 Nm	12 Nm	1 (1.0000)-8	800 lbf-in	110 lbf-in
Conversion Factor	Nm → ozf-in	141.6119	1-1/8 (1.1250)-7	900 lbf-in	137 lbf-in
	Nm → lbf-in	8.850748	1-1/4 (1.2500)-7	1000 lbf-in	165 lbf-in
	ozf-in → Nm	0.0070615	1-3/8 (1.3750)-6	1150 lbf-in	185 lbf-in
	lbf-in → Nm	0.1129848	1-1/2 (1.5000)-6	1350 lbf-in	210 lbf-in
Metric –Fine thread			UNF –Fine thread		
M8X1	6 Nm	0.8 Nm	0 (.060)-80 ⁴	---	---
M10X1	10 Nm	1.4 Nm	3 (.099)-56	32 ozf-in	7 ozf-in
M10X1.25	10 Nm	1.4 Nm	4 (.112)-48	48 ozf-in	10 ozf-in
M12X1.25	15 Nm	2.2 Nm	6 (.138)-40	6 lbf-in	1 lbf-in
M12X1.5	15 Nm	2.2 Nm	8 (.164)-36	9 lbf-in	1.5 lbf-in
M14X1.5	23 Nm	3 Nm	10 (.190)-32	13 lbf-in	2 lbf-in
M16X1.5	32 Nm	4.2 Nm	1/4 (.250)-28	30 lbf-in	3.5 lbf-in
M18X1.5	42 Nm	5.5 Nm	5/16 (.3125)-24	60 lbf-in	6.5 lbf-in
M20X1.5	54 Nm	7 Nm	3/8 (.3750)-24	80 lbf-in	9.5 lbf-in
M22X1.5	70 Nm	9 Nm	7/16 (.4375)-20	100 lbf-in	14 lbf-in
M18X2	42 Nm	5.5 Nm	1/2 (.5000)-20	150 lbf-in	18 lbf-in
M20X2	54 Nm	7 Nm	9/16 (.5625)-18	200 lbf-in	24 lbf-in
M22X2	70 Nm	9 Nm	5/8 (.6250)-18	300 lbf-in	32 lbf-in
M24X2	80 Nm	11 Nm	3/4 (.7500)-16	400 lbf-in	50 lbf-in
M27X2	95 Nm	12 Nm	7/8 (.8750)-14	600 lbf-in	70 lbf-in
M30X2	110 Nm	14 Nm	1 (1.0000)-12	800 lbf-in	90 lbf-in
M33X2	125 Nm	16 Nm	1-1/8 (1.1250)-12	900 lbf-in	117 lbf-in
M39X2	150 Nm	20 Nm	1-1/4 (1.2500)-12	1000 lbf-in	143 lbf-in
M36X3	140 Nm	18 Nm	1-3/8 (1.3750)-12	1150 lbf-in	165 lbf-in
M39X3	150 Nm	20 Nm	1-1/2 (1.5000)-12	1350 lbf-in	190 lbf-in

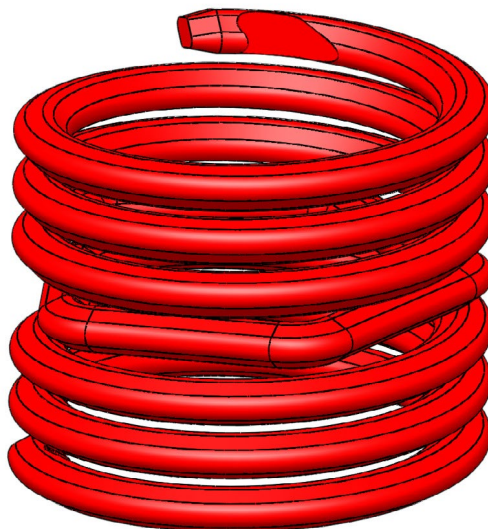

METRIC INSERT CODING

2T N M 2.5 X045 C -6.3 W SF

Type:

2T = Tangless
(Without Tang Driver)
T = Tanged
(With Tang Driver)

Style:

N = Free Running
(No coloring except for treatments)
L = Locking
(Red coloring except for treatments)

Thread:

M = Metric

Size (internal thread):

es. 2.5 = M2.5

Pitch:

ie. X045=0.45mm

Material:

C = AISI304
B = Phosphorous bronze
N = Nitronic 60
M = Nitronic 90
T = Inconel X750

Length when installed:

ie. 6.3 = 6.3mm - 2.5D

Packaging:

= Loose
SF = strip feed

Treatment:

= no coating
W = Dry-Lube
Y = Cadmium
S = Silver plated
A = Passivated
B = Blue coloring
G = Green coloring



UNC - UNF INSERT CODING

2T N C -06 C -0345 W SF

Type:

2T = Tangless
(Without Tang Driver)
T = Tanged
(With Tang Driver)

Style:

N = Free Running
(No coloring except for treatments)
L = Locking
(Red coloring except for treatments)

Pitch:

C = UNC – Coarse thread
F = UNF – Fine thread

Size (internal thread):

ie. -06 = 6-32

Material:

C = AISI304
B = Phosphorous bronze
N = Nitronic 60
M = Nitronic 90
T = Inconel X750

Length when installed:

ie. -0345 = .345" - 2.5D

Packaging:

= loose
SF = strip feed

Treatment:

= no coating
W = Dry-Lube
Y = Cadmium
S = Silver plated
A = Passivated
B = Blue coloring
G = Green coloring

Technological evolution

is a natural fact



MEASUREMENTS

Free Running inserts

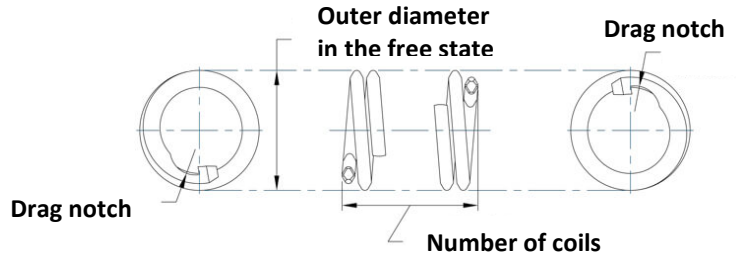

Locking inserts

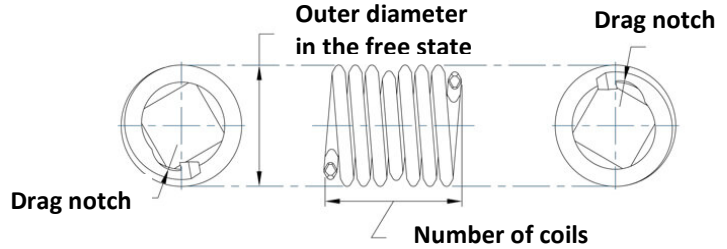
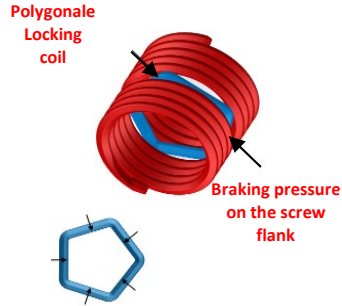

Thread	Code			Length					Ø Free state		Number of coils in the free state					Ø Hole		Ø Chamfer
	FR	SL	Thread	1d	1.5d	2d	2.5d	3d	Min	Max	1d	1.5d	2d	2.5d	3d	Alu	Acc	120°
METRIC																		
M2	2TNM	2TLM	2x0.4	2	3	4	5	6	2.50	2.70	3-1/4	5-1/2	7-3/4	10-1/8	12-3/8	2.10	2.10	2.3-2.7
M2.5	2TNM	2TLM	2.5x.45	2.5	3.8	5	6.3	7.5	3.20	3.35	3-3/8	5-3/4	8-1/8	10-1/2	12-3/4	2.55	2.65	2.9-3.4
M3	2TNM	2TLM	3x0.5	3	4.5	6	7.5	9	3.80	3.99	3-3/4	6-3/8	8-7/8	11-3/8	13-7/8	3.15	3.20	3.4-4.0
M4	2TNM	2TLM	4x0.7	4	6	8	10	12	5.05	5.28	3-5/8	6-1/8	8-5/8	11-1/8	13-5/8	4.20	4.25	4.7-5.3
M5	2TNM	2TLM	5x0.8	5	7.5	10	12.5	15	6.20	6.50	4-1/8	6-7/8	9-5/8	12-3/8	15-1/8	5.20	5.30	5.8-6.4
M6	2TNM	2TLM	6x1	6	9	12	15	18	7.40	7.78	4	6-3/4	9-1/2	12-1/8	14-7/8	6.25	6.30	7.1-7.7
M8	2TNM	2TLM	8x1.25	8	12	16	20	24	9.80	10.18	4-1/2	7-3/8	10-1/4	13-1/4	16-1/8	8.30	8.40	9.5-10.1
M10	2TNM	2TLM	10x1.5	10	15	20	25	30	11.95	12.50	4-7/8	8	11-1/8	14-1/4	17-3/8	10.50	10.50	11.8-12.4
M12	2TNM	2TLM	12x1.75	12	16	24	30	36	14.30	15.00	5	8-1/4	11-1/2	14-5/8	17-7/8	12.50	12.50	14.2-14.8
UNC																		
1-64	2TNC	2TLC	01	.073	.110	.146	.182	.219	.095	.103	2-3/4	4-7/8	6-7/8	8-7/8	10-7/8	.0785	.0810	.085-.10
2-56	2TNC	2TLC	02	.086	.129	.172	.215	.258	.110	.119	3	5-1/4	7-3/8	9-5/8	11-7/8	.0938	.0960	.09-.11
4-40	2TNC	2TLC	04	.112	.168	.224	.280	.336	.144	.159	2-3/4	4-3/4	6-3/4	8-7/8	10-7/8	.1200	.1200	.14-.17
6-32	2TNC	2TLC	06	.138	.207	.276	.345	.414	.178	.193	2-3/4	4-3/4	6-7/8	8-7/8	10-7/8	.1470	.1495	.18-.21
8-32	2TNC	2TLC	2	.164	.246	.328	.410	.492	.205	.220	3-1/2	6	8-3/8	10-3/4	13-1/4	.1730	.1770	.20-.23
10-24	2TNC	2TLC	3	.190	.285	.380	.475	.570	.244	.259	2-7/8	5	7-1/8	9-1/4	11-3/8	.2031	.2055	.24-.27
1/4-20	2TNC	2TLC	4	.250	.375	.500	.625	.750	.310	.330	3-3/8	5-3/4	8	10-3/8	13-1/8	.2660	.2660	.31-.34
5/16-18	2TNC	2TLC	5	.312	.469	.625	.781	.938	.380	.400	4	6-5/8	9-1/4	11-7/8	14-5/8	.3320	.3320	.38-.41
3/8-16	2TNC	2TLC	6	.375	.562	.750	.938	1.125	.452	.472	4-3/8	7-1/4	10	12-7/8	15-3/4	.3970	.3970	.45-.48
UNF																		
0-80	2TNF	N/A	00	.060	.090	.012	-	-	-	-	3	5-1/2	7-3/8	-	-	.0635	.0635	.08-.11
10-32	2TNF	2TLF	3	.190	.285	.380	.475	.570	.236	.256	4-1/8	6-7/8	9-1/2	12	14-7/8	.2010	.2031	.23-.26
1/4-28	2TNF	2TLF	4	.250	.375	.500	.625	.750	.306	.326	5	8-1/4	11-3/8	14-1/2	17-5/8	.2610	.2638	.29-.32
5/16-24	2TNF	2TLF	5	.312	.469	.625	.781	.938	.380	.400	5-1/2	8-7/8	12-1/4	15-5/8	19	.3281	.3281	.36-.39
3/8-24	2TNF	2TLF	6	.375	.562	.750	.938	1.125	.448	.468	6-7/8	11	15	19-1/8	23-1/8	.3906	.3906	.42-.45
7/16-20	2TNF	2TLF	7	.438	.656	.875	1.094	1.312	.524	.549	6-5/8	10-5/8	14-5/8	18-5/8	22-1/2	.4531	.4531	.50-.53
1/2-20	2TNF	2TLF	8	.500	.750	1.000	1.250	1.500	.592	.617	7-7/8	12-3/8	16-7/8	21-3/8	25-7/8	.5156	.5156	.56-.59

* Lengths 2.5d and 3d are available upon request



EQUIPMENT

Complete set of equipment for hole preparation, tapping, inspection, and installation. These are precision tools and, if used with adequate care (meaning by controlling and adjusting the installation torques) they have a very long lifespan. The driving hook can easily reach over 10,000 installations; once worn, it can be replaced without the need to discard the entire tool, which can have a very high durability.

Pneumatic

Electric

Manual



Tangless®

MANUAL INSTALLATION TOOL WITH PRE-WINDER

They have always been the safest and most reliable system for installing threaded inserts, especially in smaller sizes (M2.5-M3). They have a pre-winder nose that reduces the thread diameter and aligns it perfectly. The same tool can install both Free Running and Locking inserts. Recommended for low installation volumes.

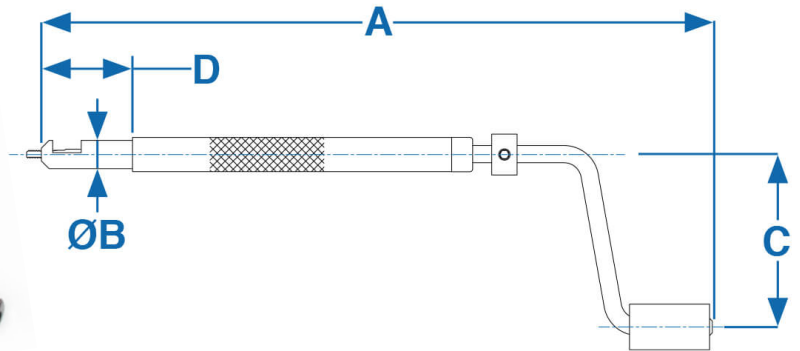



SIZE	 Tool	 Replacement hook	 Kit: 1 hook 2 springs - 2 pins	A	B	C	D	
METRIC								
M2.5	2KPHM-2.5 (TCIM-2.5)	2KIPM-2.5 (TCIM-2.5P)	2KIPM-2.5K	7.47" - 190mm	0.38" - 9.65mm	2.28" - 58mm	1.00" - 25.4mm	
M3	2KPHM-3 (TCIM-3)	2KIPM-3 (TCIM-3P)	2KIPM-3K	7.47" - 190mm	0.38" - 9.65mm	2.28" - 58mm	0.99" - 25mm	
M4	2KPHM-4 (TCIM-4)	2KIPM-4 (TCIM-4P)	2KIPM-4K	7.47" - 190mm	0.38" - 9.65mm	2.28" - 58mm	1.00" - 25.4mm	
M5	2KPHM-5 (TCIM-5)	2KIPM-5 (TCIM-5P)	2KIPM-5K	7.47" - 190mm	0.44" - 11.2mm	2.28" - 58mm	1.00" - 25.4mm	
M6	2KPHM-6 (TCIM-6)	2KIPM-6 (TCIM-6P)	2KIPM-6K	7.97" - 202mm	0.44" - 11.2mm	2.28" - 58mm	1.25" - 32mm	
M8	2KPHM-8 (TCIM-8)	2KIPM-8 (TCIM-8P)	2KIPM-8K	7.97" - 202mm	0.50" - 12.7mm	2.53" - 64mm	-	
M10	2KPHM-10 (TCIM-10)	2KIPM-10 (TCIM-10P)	2KIPM-10K	7.97" - 202mm	0.69" - 17.5mm	2.94" - 75mm	-	
M12	2KPHM-12 (TCIM-12)	2KIPM-12 (TCIM-12P)	2KIPM-12K	7.97" - 202mm	0.83 - 21mm	2.94" - 75mm	-	
UNC								
2-56	2KPHC-02 (TCIC-02)	2KIPC-02 (TCIC-02P)	2KIPC-02K	7.47" - 190mm	0.38" - 9.65mm	2.28" - 58mm	0.98" - 25mm	
4-40	2KPHC-04 (TCIC-04)	2KIPC-04 (TCIC-04P)	2KIPC-04K	7.47" - 190mm	0.38" - 9.65mm	2.28" - 58mm	0.99" - 25mm	
6-32	2KPHC-06 (TCIC-06)	2KIPC-06 (TCIC-06P)	2KIPC-06K	7.47" - 190mm	0.38" - 9.65mm	2.28" - 58mm	1.00" - 25.4mm	
8-32	2KPHC-2 (TCIC-2)	2KIPC-2 (TCIC-2P)	2KIPC-2K	7.47" - 190mm	0.38" - 9.65mm	2.28" - 58mm	1.00" - 25.4mm	
10-24	2KPHC-3 (TCIC-3)	2KIPC-3 (TCIC-3P)	2KIPC-3K	7.47" - 190mm	0.44" - 11.2mm	2.28" - 58mm	1.00" - 25.4mm	
1/4-20	2KPHC-4 (TCIC-4)	2KIPC-4 (TCIC-4P)	2KIPC-4K	7.97" - 202mm	0.50" - 12.7mm	2.53" - 64mm	1.25" - 32mm	
5/16-18	2KPHC-5 (TCIC-5)	2KIPC-5 (TCIC-5P)	2KIPC-5K	7.97" - 202mm	0.63" - 16mm	2.94" - 75mm	-	
3/8-16	2KPHC-6 (TCIC-6)	2KIPC-6 (TCIC-6P)	2KIPC-6K	7.97" - 202mm	0.69" - 17.5mm	2.94" - 75mm	-	
UNF								
10-32	2KPHF-3 (TCIF-3)	2KIPF-3 (TCIF-3P)	2KIPF-3K	7.47" - 190mm	0.50" - 12.7mm	2.28" - 58mm	0.99" - 25mm	
1/4-28	2KPHF-4 (TCIF-4)	2KIPF-4 (TCIF-4P)	2KIPF-4K	7.47" - 190mm	0.50" - 12.7mm	2.53" - 64mm	1.24" - 32mm	
5/16-24	2KPHF-5 (TCIF-5)	2KIPF-5 (TCIF-5P)	2KIPF-5K	7.47" - 190mm	0.63" - 16mm	2.94" - 75mm	-	
3/8-24	2KPHF-6 (TCIF-6)	2KIPF-6 (TCIF-6P)	2KIPF-6K	7.47" - 190mm	0.69" - 17.5mm	2.94" - 75mm	-	
7/16-20	2KPHF-7 (Free Running)	2KPHL-7 (Locking)	2KIPF-7	2KIPF-7K	7.47" - 190mm	0.69" - 17.5mm	2.94" - 75mm	-
1/2-20	2KPHF-8 (Free Running)	2KPHL-8 (Locking)	2KIPF-8	2KIPF-8K	7.47" - 190mm	0.69" - 17.5mm	2.94" - 75mm	-

ROD INSTALLATION TOOL

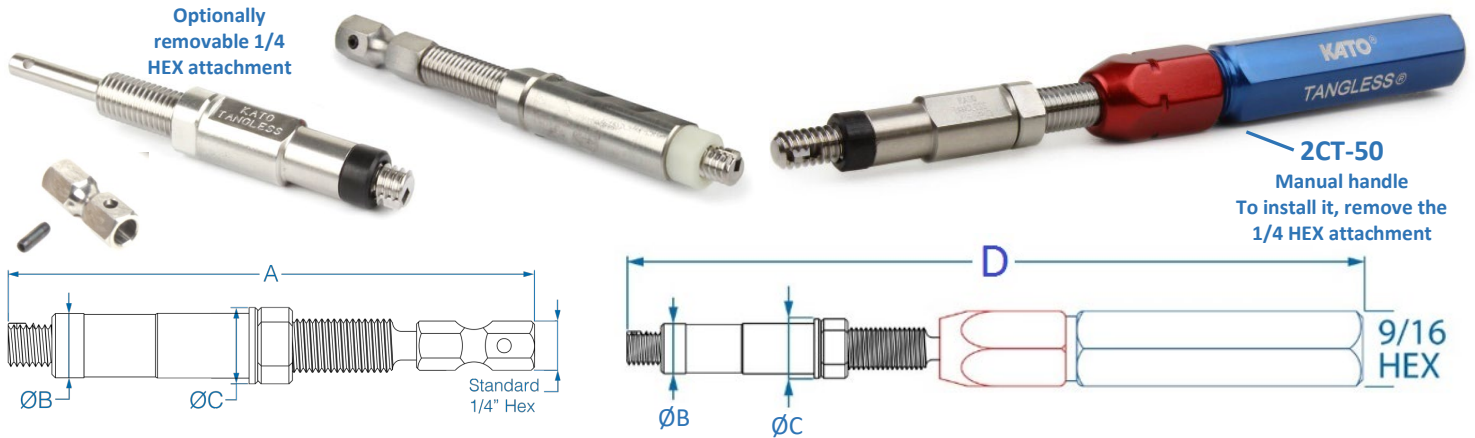
They have both hexagonal and cylindrical attachments for use with power tools and a convenient screwdriver-like handle for manual use. Great speed in operations with medium to high production batches. For metric pitches, there are separate tools for Free-Running and Locking inserts. The rods have a very long lifespan; it is sufficient to replace the hook when worn. For mounting the aluminum handle, the hexagon must be removed by extracting the side retaining pin. The model for 0-80 is for manual use only.





SIZE					A	B	C	D
	Free Running tool	Locking tool						
METRIC								
M2	2CT10-M2F	2CT10-M2F	2CT20-M2	-	69mm	6.3mm	9.5mm	122mm
M2.5	2CT10-M2.5F	2CT10-M2.5L	2CT20-M2.5	-	69mm	6mm	9.5mm	122mm
M3	2CT10-M3F	2CT10-M3L	2CT20-M3	-	69mm	7mm	9.5mm	122mm
M4	2CT10-M4F	2CT10-M4L	2CT20-M4	-	76mm	9mm	11mm	129mm
M5	2CT10-M5F	2CT10-M5L	2CT20-M5	-	79mm	10mm	11mm	132mm
M6	2CT10-M6F	2CT10-M6L	2CT20-M6	-	79mm	11mm	11mm	132mm
M8	2CT10-M8F	2CT10-M8L	2CT20-M8	-	99mm	13mm	13mm	152mm
M10	2CT10-M10	2CT10-M10	2CT20-M10	-	105mm	15.5mm	15.5mm	158mm
M12	2CT10-M12	2CT10-M12	2CT20-M12	-	115mm	17.5mm	17.5mm	168mm
UNC								
1-64	2KHEC-01		2KIPC-01	2KIPC-01K	2.84"	0.24"	0.38"	5.18"
2-56	2KHEC-02 (CT16002-02)		2KIPC-02 (CT16402-02K)	2KIPC-02K	2.84"	0.24"	0.37"	5.16"
4-40	2KHEC-04 (CT16002-04)		2KIPC-04 (CT16402-04K)	2KIPC-04K	2.95"	0.24"	0.37"	5.33"
6-32	2KHEC-06 (CT16002-06)		2KIPC-06 (CT16402-06K)	2KIPC-06K	2.94"	0.38"	0.37"	5.36"
8-32	2KHEC-2 (CT16002-2)		2KIPC-2 (CT16402-2K)	2KIPC-2K	2.99"	0.32"	0.37"	5.6"
10-24	2KHEC-3 (CT16002-3)		2KIPC-3 (CT16402-3K)	2KIPC-3K	3.00"	0.38"	0.37"	5.41"
1/4-20	2KHEC-4 (CT16002-4)		2KIPC-4 (CT16402-4K)	2KIPC-4K	3.00"	0.37"	0.44"	5.49"
5/16-18	2KHEC-5		2KIPC-5	2KIPC-5K		0.71"	0.71"	5.74"
3/8-16	2KHEC-6		2KIPC-6	2KIPC-6K		0.71"	0.71"	5.76"
UNF								
0-80	2KREF-00 <small>MANUAL USE ONLY</small>	-	-	-	-	-	-	-
10-32	2KHEF-F3 (CT16003-3)	2KHEF-L3	2KIPF-3 (CT16403-3K)	2KIPF-3K	3.11"	0.38"	0.44"	5.67"

REMOVAL TOOL

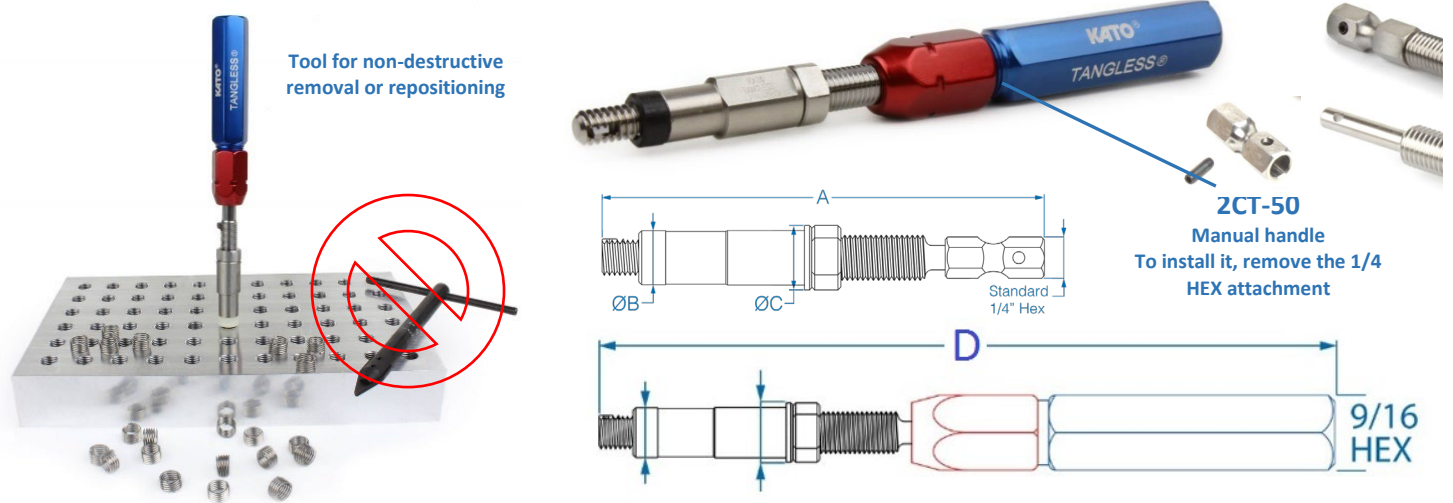
The extraction tool has a configuration identical to the installation rod. The difference lies in the extraction tang, which allows the removal of the insert with a screwing operation, avoiding damage to the component, the threading, and the insert. It can also be used to correct the insertion depth of the insert during adjustment phases.



SIZE					A	B	C	D
	Free Running tool	Locking tool						
METRIC								
M2	2CT30-M2F	2CT30-M2F	2CT40-M2	-	69mm	6.3mm	9.5mm	122mm
M2.5	2CT30-M2.5F	2CT30-M2.5L	2CT40-M2.5	-	69mm	6mm	9.5mm	122mm
M3	2CT30-M3F	2CT30-M3L	2CT40-M3	-	69mm	7mm	9.5mm	122mm
M4	2CT30-M4F	2CT30-M4L	2CT40-M4	-	76mm	9mm	11mm	129mm
M5	2CT30-M5F	2CT30-M5L	2CT40-M5	-	79mm	10mm	11mm	132mm
M6	2CT30-M6F	2CT30-M6L	2CT40-M6	-	79mm	11mm	11mm	132mm
M8	2CT30-M8F	2CT30-M8L	2CT40-M8	-	99mm	13mm	13mm	152mm
M10	2CT30-M10	2CT30-M10	2CT40-M10	-	105mm	15.5mm	15.5mm	158mm
M12	2CT30-M12	2CT30-M12	2CT40-M12	-	115mm	17.5mm	17.5mm	168mm
UNC								
1-64	2KRTC-01		2KRPC-01	2KRPC-01K	2.84"	0.24"	0.38"	5.18"
2-56	2KRTC-02 (CT16002R-02)		2KRPC-02 (CT16402R-02K)	2KRPC-02K	2.84"	0.24"	0.37"	5.16"
4-40	2KRTC-04 (CT16002R-04)		2KRPC-04 (CT16402R-04K)	2KRPC-04K	2.95"	0.24"	0.37"	5.33"
6-32	2KRTC-06 (CT16002R-06)		2KRPC-06 (CT16402R-06K)	2KRPC-06K	2.94"	0.38"	0.37"	5.36"
8-32	2KRTC-2 (CT16002R-2)		2KRPC-2 (CT16402R-2K)	2KRPC-2K	2.99"	0.32"	0.37"	5.6"
10-24	2KRTC-3 (CT16002R-3)		2KRPC-3 (CT16402R-3K)	2KRPC-3K	3.00"	0.38"	0.37"	5.41"
1/4-20	2KRTC-4 (CT16002R-4)		2KRPC-4 (CT16402R-4K)	2KRPC-4K	3.00"	0.37"	0.44"	5.49"
5/16-18	2KRTC-5		2KRPC-5	2KRPC-5K		0.71"	0.71"	5.74"
3/8-16	2KRTC-6		2KRPC-6	2KRPC-6K		0.71"	0.71"	5.76"
UNF								
0-80	2KREF-00 MANUAL USE ONLY	-	2KRPF-00	-		0.24"	0.27"	3.52"
10-32	2KRTF-3 (CT16003R-3)		2KRPF-3 (CT16403R-3K)	2KRPF-3K	3.00"	0.38"	0.44"	5.67"
1/4-28	2KRTF-4		2KRPF-4	2KRPF-4K	3.00"	0.37"	0.44"	5.46"
5/16-24	2KRTF-5		2KRPF-5	2KRPF-5K		0.71"	0.71"	5.74"
3/8-24	2KRTF-6		2KRPF-6	2KRPF-6K		0.71"	0.71"	5.76"
7/16-20	2KRTF-7		2KRPF-7	2KRPF-7K		0.71"	0.71"	5.76"
1/2-20	2KRTF-8		2KRPF-8	2KRPF-8K		0.71"	0.71"	5.76"

KFS-20 and KFS-25 ELECTRIC INSTALLATION TOOLS

Ideal for applications with medium to high installation volumes, the tool is lightweight, easy to use, and quiet. It has a clutch to prevent damage to the rods and automatic reverse for disengagement. It allows for quick change of the installation tool to quickly switch to installing a different size. It is used with 1/4HEX rod installation or removal tools.

KFS-20 usage range: M2 – M6 and 2-56 – 1/4.

KFS-25 usage range: M4 - M12 and 6-32 - 1/2”.



KFS-20 ELECTRIC TOOL

Code	Torque	Speed	Length A	Diameter B	Diameter C	Handle Diameter	Weight	Attachment	Volt
KFS-20 (CT5420)	0.1-0.7 Nm 0.62-0.88 lbf-in	LOW 480 g/min	216mm 8.5"	11mm 0.428"	28mm 1.1"	33mm 1.28"	363 gr 12.8 oz	1/4 HEX	20-30 VDC
KFS-25(CT5425)	0.5-2.0 Nm 4.4-17.7 lbf-in	LOW 490 g/min HIGH 730 g/min	230mm 9.05"	13mm 0.51"	15mm 0.60"	38mm 1.49"	408 gr 14.4 oz	1/4 HEX	20-30 VDC

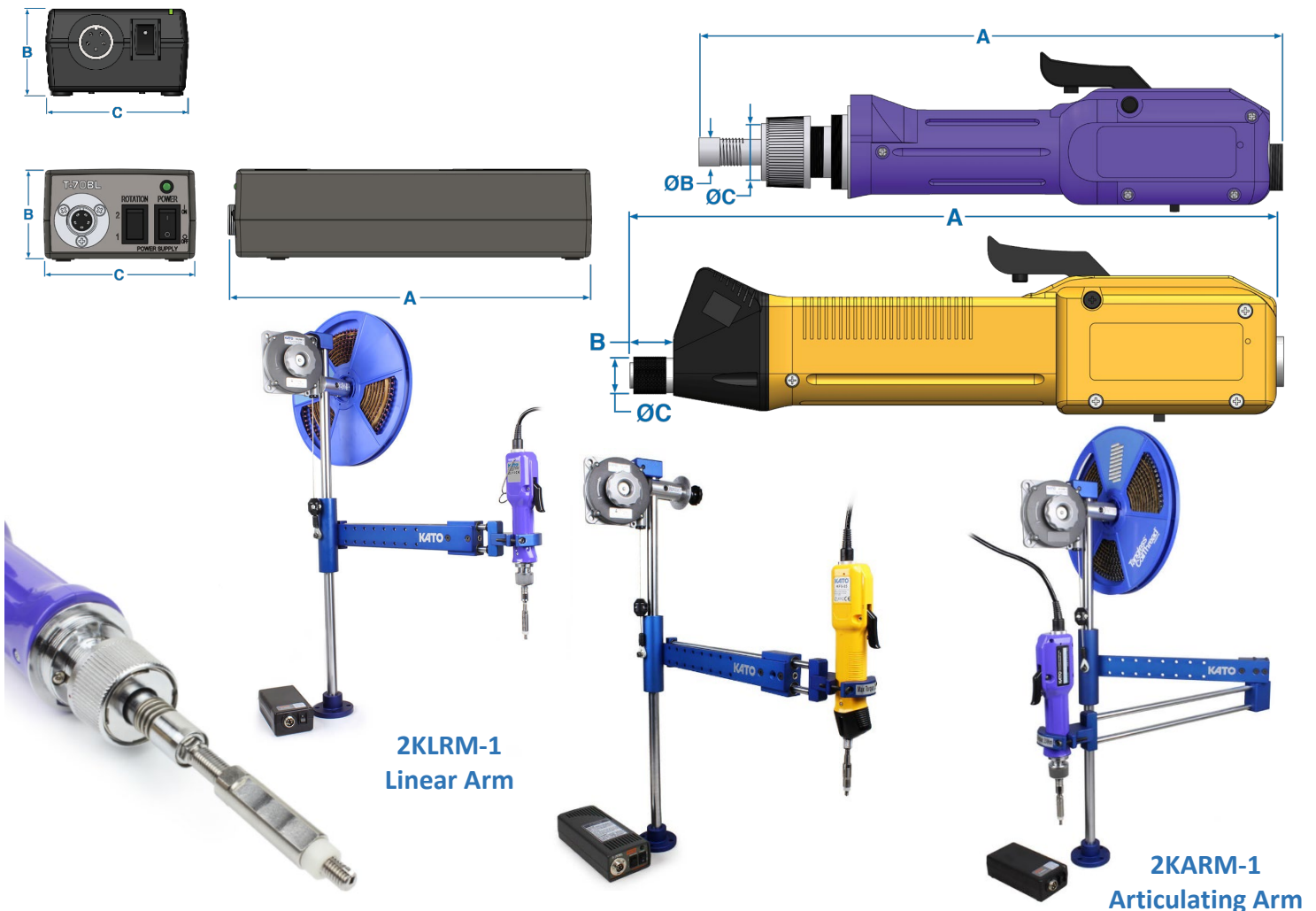

KFS-20 ELECTRIC INSTALLATION TOOL WITH PREWINDER

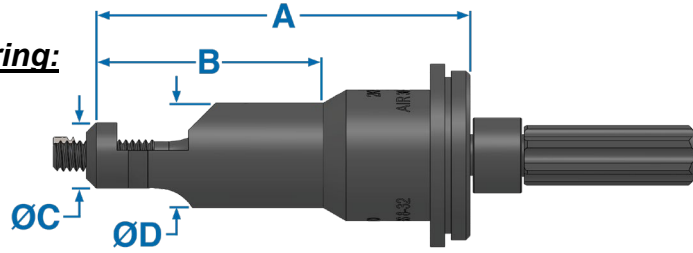

Combining the features of an electric tool with those of a pneumatic one, it is quiet and does not require compressed air. It allows for the installation of medium to high volumes of inserts, both on plastic strips and loose. From M2.5 to M6 and from 2-56 to 1/4".

It is composed by ordering:
KFS-20 Electric tool
CT5420-PA Adapter
2KPEX-xx Nosepiece



**CT5420-PA
Adapter for
KFS-12**



SIZE				A	B	C	D
METRIC							
M2.5	2KPEM-2.5	2KIPM-2.5	2KIPM-2.5K	1.69" - 42.9mm	1.47" - 37.4mm	0.39" - 9.9mm	0.39" - 9.9mm
M3	2KPEM-3	2KIPM-3	2KIPM-3K	1.69" - 42.9mm	1.38" - 35mm	0.37" - 9.4mm	0.51" - 13mm
M4	2KPEM-4	2KIPM-4	2KIPM-4K	1.65" - 41.9mm	1.02" - 25.9mm	0.35" - 8.9mm	0.49" - 12.5mm
M5	2KPEM-5	2KIPM-5	2KIPM-5K	1.75" - 44.5mm	1" - 25.4mm	0.24" - 6.1mm	0.39" - 9.9mm
M6	2KPEM-6	2KIPM-6	2KIPM-6K	1.65" - 41.9mm	1.48" - 37.6mm	0.39" - 9.9mm	0.63" - 16mm
UNC							
2-56	2KPEC-02	2KIPC-02	2KIPC-02K	1.69" - 42.9mm	0.97" - 24.6mm	0.18" - 4.6mm	0.34" - 8.6mm
4-40	2KPEC-04	2KIPC-04	2KIPC-04K	1.69" - 42.9mm	1.09" - 27.6mm	0.26" - 6.6mm	0.40" - 10.2mm
6-32	2KPEC-06	2KIPC-06	2KIPC-06K	1.85" - 47mm	1.25" - 31.8mm	0.31" - 7.9mm	0.50" - 12.7mm
8-32	2KPEC-2	2KIPC-2	2KIPC-2K	1.85" - 47mm	1.05" - 26.7mm	0.35" - 8.9mm	0.51" - 13mm
10-24	2KPEC-3	2KIPC-3	2KIPC-3K	1.85" - 47mm	1.34" - 34mm	0.37" - 9.4mm	0.51" - 13mm
1/4-20	2KPEC-4	2KIPC-4	2KIPC-4K	1.65" - 41.9mm	1.44" - 36.5mm	0.42" - 10.7mm	0.63" - 16mm
UNF							
10-32	2KPEF-3	2KIPF-3	2KIPF-3K	1.95" - 49.5mm	1.02" - 25.9mm	0.38" - 9.7mm	0.62" - 15.8mm
1/4-28	2KPEF-4	2KIPF-4	2KIPF-4K	1.65" - 41.9mm	1.23" - 32.3mm	0.43" - 10.9mm	0.63" - 16mm

Other replacement parts:

Complete replacement shaft: add the suffix **M** at the end of the nosepiece code

Nosepiece replacement body: add the suffix **D** at the end of the nosepiece code

Spacers kit (3 spacers, 1 thick shim, 3 thin shims): add the suffix **S** at the end of the nosepiece code



PNEUMATIC INSTALLATION TOOL

For the installation of medium to high batches using inserts on plastic strips. It is recommended to use the torque-adjustable clutch when installing threads from M2.5 to M4 and from 2-56 to 4-40.



SIZE	 Nosepiece	 Replacement hook	 Kit: 1 hook 2 springs - 2 pins	 Clutch	 Adapter	 Motor
METRIC						
M2.5	2KPAM-2.5	2KIPM-2.5	2KIPM-2.5K	CT9602	CT9605	CT25017
M3	2KPAM-3	2KIPM-3	2KIPM-3K			
M4	2KPAM-4	2KIPM-4	2KIPM-4K			
M5	2KPAM-5	2KIPM-5	2KIPM-5K	CT9705		
M6	2KPAM-6	2KIPM-6	2KIPM-6K			
M8	2KPAM-8	2KIPM-8	2KIPM-8K			
M10	2KPAM-10	2KIPM-10	2KIPM-10K			
M12	2KPAM-12	2KIPM-12	2KIPM-12K			
UNC						
2-56	2KPAC-02	2KIPC-02	2KIPC-02K	CT9602	CT9605	CT25017
4-40	2KPAC-04	2KIPC-04	2KIPC-04K			
6-32	2KPAC-06	2KIPC-06	2KIPC-06K			
8-32	2KPAC-2	2KIPC-2	2KIPC-2K	CT9705		
10-24	2KPAC-3	2KIPC-3	2KIPC-3K			
1/4-20	2KPAC-4	2KIPC-4	2KIPC-4K			
5/16-18	2KPAC-5	2KIPC-5	2KIPC-5K			
3/8-16	2KPAC-6	2KIPC-6	2KIPC-6K			
UNF						
10-32	2KPAF-3	2KIPF-3	2KIPF-3K		CT9605	CT25017
1/4-28	2KPAF-4	2KIPF-4	2KIPF-4K			
5/16-24	2KPAF-5	2KIPF-5	2KIPF-5K			
3/8-24	2KPAF-6	2KIPF-6	2KIPF-6K	CT9705		
7/16-20	2KPAF-F7 Free Running	2KPAF-L7 Locking	2KIPF-7			
1/2-20	2KPAF-F8 Free Running	2KPAF-L8 Locking	2KIPF-8			

Other replacements:

Complete replacement shaft: add the suffix **M** at the end of the nosepiece code

Nosepiece replacement body: add the suffix **D** at the end of the nosepiece code

Spacers kit (3 spacers, 1 thick shim, 3 thin shims): add the suffix **S** at the end of the nosepiece code



GO-NO GO THREAD GAUGES

Threaded inserts acquire the tolerance class of the tapping on which they are installed. It is recommended to use taps with a class of **5H** or **4H**, especially for the installation of self-locking inserts, to obtain appropriate braking values. It is necessary to perform thread checks with a GO-NO GO thread gauge.

Thread	M 6H	MJ 4H5H
M2	CGM-2X0.4-6H	CGMJ-2X0.4-4H
M2.5	CGM-2.5X0.45-6H	CGMJ-2.5X0.45-4H
M3	CGM-3X0.5-6H	CGMJ-3X0.5-4H
M4	CGM-4X0.7-6H	CGMJ-4X0.7-4H
M5	CGM-5X0.8-6H	CGMJ-5X0.8-4H
M6	CGM-6X1-6H	CGMJ-6X1-4H
M8	CGM-8X1.25-6H	CGMJ-8X1.25-4H
M10	CGM-10X1.5-6H	CGMJ-10X1.5-4H
M12	CGM-12X1.75-6H	

Thread	UN 2B	UN 3B	UNJ 3B
2-56 UNC	CGC-02X-2B	CGC-02X-3B	CGCJ-02X-3B
4-40 UNF	CGC-04X-2B	CGC-04X-3B	CGCJ-04X-3B
6-32 UNC	CGC-06X-2B	CGC-06X-3B	CGCJ-06X-3B
8-32 UNC	CGC-2X-2B	CGC-2X-3B	CGCJ-2X-3B
10-24 UNC	CGC-3X-2B	CGC-3X-3B	CGCJ-3X-3B
1/4-20 UNC	CGC-4X-2B	CGC-4X-3B	CGCJ-4X-3B
5/16-18 UNC	CGC-5X-2B	CGC-5X-3B	CGCJ-5X-3B
3/8-16 UNC	CGC-6X-2B	CGC-6X-3B	CGCJ-6X-3B
10-32 UNF	CGF-3X-2B	CGF-3X-3B	CGFJ-3X-3B
1/4-28 UNF	CGF-4X-2B	CGF-4X-3B	CGFJ-4X-3B
5/16-24 UNF	CGF-5X-2B	CGF-5X-3B	CGFJ-5X-3B
3/8-24 UNF	CGF-6X-2B	CGF-6X-3B	CGFJ-6X-3B



PRO KITS TANGLESS

Contents: 1 drill, 1 tap, (6H, 2B), 1 installation tool, 30 inserts (10pz 1D, 10pz 1.5D, 10pz 2D)

Size	Kit code	1D Inserts code	1.5D insert code	2D inserts code
M2.5x0.45	2KPRM-2.5	2KPRM-2.5-10	2KPRM-2.5-15	2KPRM-2.5-20
M3x0.5	2KPRM-3	2KPRM-3-10	2KPRM-3-15	2KPRM-3-20
M4x0.7	2KPRM-4	2KPRM-4-10	2KPRM-4-15	2KPRM-4-20
M5x0.8	2KPRM-5	2KPRM-5-10	2KPRM-5-15	2KPRM-5-20
M6x1	2KPRM-6	2KPRM-6-10	2KPRM-6-15	2KPRM-6-20
M8x1.25	2KPRM-8	2KPRM-8-10	2KPRM-8-15	2KPRM-8-20
M10x1.5	2KPRM-10	2KPRM-10-10	2KPRM-10-15	2KPRM-10-20
M12x1.75	2KPRM-12	2KPRM-12-10	2KPRM-12-15	2KPRM-12-20
2-56	2KPRC-02	2KPRC-02-10	2KPRC-02-15	2KPRC-02-20
4-40	2KPRC-04	2KPRC-04-10	2KPRC-04-15	2KPRC-04-20
6-32	2KPRC-06	2KPRC-06-10	2KPRC-06-15	2KPRC-06-20
8-32	2KPRC-2	2KPRC-2-10	2KPRC-2-15	2KPRC-2-20
10-24	2KPRC-3	2KPRC-3-10	2KPRC-3-15	2KPRC-3-20
1/4-20	2KPRC-4	2KPRC-4-10	2KPRC-4-15	2KPRC-4-20
5/16-18	2KPRC-5	2KPRC-5-10	2KPRC-5-15	2KPRC-5-20
3/8-16	2KPRC-6	2KPRC-6-10	2KPRC-6-15	2KPRC-6-20
7/16-14*	2KPRC-7	2KPRC-7-10	2KPRC-7-15	2KPRC-7-20
1/2-13*	2KPRC-8	2KPRC-8-10	2KPRC-8-15	2KPRC-8-20
10-32	2KPRF-3	2KPRF-3-10	2KPRF-3-15	2KPRF-3-20
1/4-28	2KPRF-4	2KPRF-4-10	2KPRF-4-15	2KPRF-4-20
5/16-24	2KPRF-5	2KPRF-5-10	2KPRF-5-15	2KPRF-5-20
3/8-24	2KPRF-6	2KPRF-6-10	2KPRF-6-15	2KPRF-6-20
7/16-20	2KPRF-7	2KPRF-7-10	2KPRF-7-15	2KPRF-7-20
1/2-20	2KPRF-8	2KPRF-8-10	2KPRF-8-15	2KPRF-8-20



*upon request

INSTALLATION – Metric and unified pitches, with and without tang driver

Threaded inserts are designed to be installed in holes with suitable tapping and take the tolerance of the housing thread. For example, tapping for threaded inserts M6 (sometimes defined as EG-M6 or STI M6) with a tap in tolerance EG-M6 6H or STI-M6 6H, will produce an M6 6H thread once the insert is installed.

A correct execution of the mechanical processing of the insert housing determines the final tolerance class and facilitates the installation of threaded inserts. An incorrect execution of the housing tapping, in addition to being a potential cause of non-compliance, is often the cause of installation problems for threaded inserts.

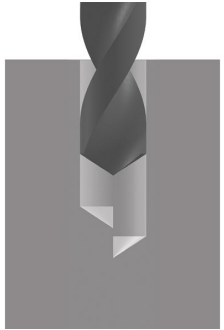

Step 1 – Drilling

The drill diameter and drilling depth must be chosen based on the data provided by the drilling tables below. The tapping diameters must comply with the NASM33537 and MA1567 standards and must be measured after tapping operations and any subsequent treatments (anodizing, chemical film, etc.).

The recommended pilot hole is to be taken as a suggestion based on the characteristics of the material to be drilled and to allow for a long life of the tap on tough materials. These are average values that are adequate for most applications, but there may be specific applications that require variations to achieve the correct tapping diameters and tolerances. For example, adjustments should be made in case of coatings or treatments (anodizing, chemical film, etc.).

The drilling depth for blind holes depends on the thread installation method. Consideration should be given to any countersink of the hole, the type of tap used, and whether the tang, if used, is removed (Tangless® threads have no tang). Threaded inserts are typically installed from $\frac{3}{4}$ to $1\frac{1}{2}$ times the pitch below the surface of the countersunk hole. They can also be installed at different depths in cases of specific space limitations. Without countersinking, inserts can be installed from $\frac{1}{4}$ to $\frac{1}{2}$ times the pitch below the surface.

The minimum material thickness, in case no countersink is made, is the nominal thickness of the thread to be installed ($1 - 1.5 - 2 - 2.5 - 3 d$)

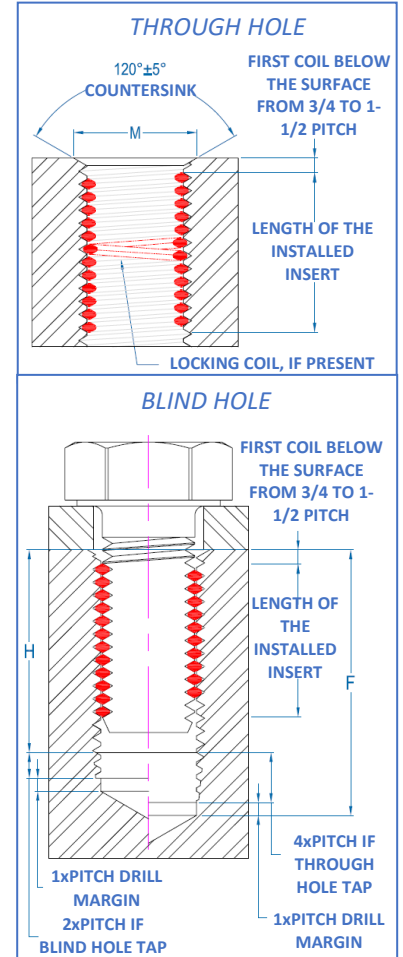

Step 2 – Countersink

Before tapping, it is advisable to countersink the hole at $120^\circ + 5^\circ$ with a diameter equal to M, as indicated in the tables. This helps avoid thin material ridges at the hole entrance, which can be easily damaged. The 120° countersink is used because 60° on each side is the same angle as the thread and the insert's wire section. This combination makes the insert installation operation faster and safer. The values F and H are calculated with a countersink depth of $\frac{1}{2}$ the pitch.

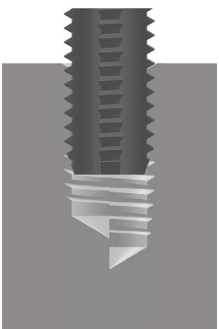

Step 3 – Tapping

For the depth of tapping in blind holes, the type of tap used must be considered. Refer to the tables for indicative data to guide you. The tapping depth parameter in the table is calculated considering a normal installation with countersinking. If countersinking is not performed, the depth can be reduced. The H or B tolerance class of the finished thread with the installed insert depends on the tap tolerance. The installed insert will have a tolerance within the parameters of the tap tolerance. Typically, the tighter 4H or 3B class is used in military or aerospace applications and is recommended for use with locking threads to achieve better braking parameters and where greater security is required. The 5H or 6H or 2B class is suitable for most industrial and commercial applications and for repairing damaged threads.

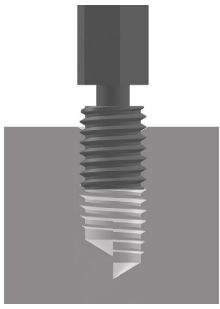

Step 4 – Inspection

The thread tolerance class must be achieved before installing the insert. Any treatments or surface coatings can significantly alter the thread tolerance, requiring further adjustments. It is always advisable to perform thread checks with a GO-NO GO gauge. It is not necessary to check the installed insert, as it takes on the tolerance of the tap, and attempting to check the insert after installation is likely to fail because the insert settles with the assembly and tightening of the screw. Additionally, it is impossible to check a Locking insert due to the presence of the braking coil preventing the passage of the plug gauge.

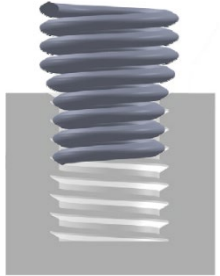

Step 5 – Installation

The installation depth depends on the presence of a countersink. From $\frac{3}{4}$ to $1\frac{1}{2}$ turns below the surface if a countersink is present, $\frac{1}{4}$ to $\frac{1}{2}$ turn below the surface if it isn't. Tangless inserts can be installed with various manual, electric, or pneumatic tools. The choice of the most effective installation tool depends on various factors. Consult with our technicians, and they will be able to suggest the suitable system based on your application.

When using Tangless inserts (without a tang), there are no additional operations to be performed.

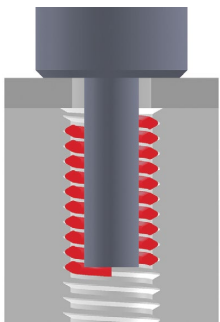

Step 6 – Tang removal

The removal of the tang is always recommended to ensure that the insert is threaded through the maximum number of coils, thus ensuring better retention and greater locking torque when using self-locking inserts. The removal of the tang is also mandatory in all military and aerospace applications and advisable in all critical applications, as under heavy loads, the tang can break and cause damage to equipment. The tang removal can be done with pliers for larger diameters or with a punch slightly smaller than the internal diameter of the threaded insert or with specific automatic spring-loaded tang break-off tools.



Removal of the threaded insert

Should any installation error occur, the threaded insert can be removed from its seat using the appropriate removal tools.

Tangless Inserts: The tool has a similar configuration to the installation one. The difference lies in the extraction hook, which allows the removal of the insert with an unscrewing operation, avoiding damage to the part, thread, and insert. It can also be used to adjust the insertion depth of the insert. The operation is non-destructive and does not cause any damage to the inserts.

Tanged inserts: The tool appears as a sharp wedge with a T-handle. The blade must be inserted into the first coil of the insert (a hammer may be necessary). After that, it is rotated counterclockwise while continuing to apply pressure until the insert is unscrewed. Extraction is possible only if the insert is not installed too deeply, and the wedge blade can reach the first coil. The extraction operation of tanged inserts often causes damage to the part.



Tangless removal tool



Tanged removal tool

DRILLING – METRIC THREAD

Thread size	Min. diameter (after tapping)		Suggested drill diameter *		Countersink diameter (120° +/-5°)		Mean diameter			Height H Minimum tapping depth					Max Tap Ø
	Min	Max	Aluminum	Steel	Min	Max	Min	Max 4H	Max 5H	1d	1.5d	2d	2.5d	3d	
Metric – Coarse thread															
M2X0.4	2.087	2.199	2.10	2.10	2.30	2.70	2.260	2.295	2.310	2.4	3.4	4.4	5.4	6.4	2.581
M2.2X0.45	2.297	2.422	2.30	2.35	2.60	3.00	2.492	2.532	2.547	2.7	3.8	4.9	6.0	7.1	2.845
M2.5X0.45	2.597	2.722	2.55	2.65	2.90	3.40	2.792	2.832	2.847	3.0	4.2	5.5	6.7	8.0	3.147
M3X0.5	3.108	3.248	3.15	3.20	3.40	4.00	3.325	3.367	3.384	3.5	5.0	6.5	8.0	9.5	3.716
M3.5X0.6	3.630	3.790	3.70	3.70	4.10	4.70	3.890	3.940	3.959	4.1	5.9	7.6	9.4	11.1	4.354
M4X0.7	4.152	4.332	4.20	4.25	4.70	5.30	4.455	4.509	4.529	4.7	6.7	8.7	10.7	12.7	5.006
M5X0.8	5.174	5.374	5.20	5.30	5.80	6.40	5.520	5.577	5.597	5.8	8.3	10.8	13.3	15.8	6.142
M6X1	6.217	6.407	6.25	6.30	7.10	7.70	6.650	6.719	6.742	7.0	10.0	13.0	16.0	19.0	7.422
M7X1	7.217	7.407	7.25	7.30	8.10	8.70	7.650	7.719	7.742	8.0	11.5	15.0	18.5	22.0	8.423
M8X1.25	8.271	8.483	8.30	8.40	9.50	10.10	8.812	8.886	8.911	9.3	13.3	17.3	21.3	25.3	9.787
M10X1.5	10.324	10.560	10.50	10.50	11.80	12.40	10.974	11.061	11.089	11.5	16.5	21.5	26.5	31.5	12.131
M12X1.75*	12.379	12.644	12.50	12.50	14.20	14.80	13.137	13.236	13.271	13.8	19.8	25.8	31.8	37.8	14.478
M14X2	14.433	14.733	14.50	14.50	16.50	17.10	15.299	15.406	15.444	16.0	23.0	30.0	37.0	44.0	16.822
M16X2	16.433	16.733	16.50	16.50	18.50	19.10	17.299	17.406	17.444	18.0	26.0	34.0	42.0	50.0	18.821
M18X2.5	18.541	18.896	18.75	18.75	21.20	21.80	19.624	19.738	19.778	20.5	29.5	38.5	47.5	56.5	21.514
M20X2.5	20.541	20.896	20.75	20.75	23.20	23.80	21.624	21.738	21.778	22.5	32.5	42.5	52.5	62.5	23.513
M22X2.5	22.541	22.896	22.75	22.75	25.20	25.80	23.624	23.738	23.778	24.5	35.5	46.5	57.5	68.5	25.512
M24X3	24.649	25.049	24.75	24.75	27.90	28.50	25.948	26.093	26.135	27.0	39.0	51.0	63.0	75.0	28.237
M27X3	27.649	28.049	27.75	27.75	30.90	31.50	28.948	29.093	29.135	30.0	43.5	57.0	70.5	84.0	31.238
Metric – Fine thread															
M8X1	8.217	8.407	8.25	8.30	9.10	9.70	8.650	8.719	8.742	9.0	13.0	17.0	21.0	25.0	9.423
M10X1	10.217	10.407	10.25	10.25	11.10	11.70	10.650	10.719	10.742	11.0	16.0	21.0	26.0	31.0	11.422
M10X1.25*	10.271	10.483	10.25	10.25	11.50	12.10	10.812	10.886	10.911	11.3	16.3	21.3	26.3	31.3	11.788
M12X1.25*	12.271	12.483	12.25	12.25	13.50	14.10	12.812	12.898	12.926	13.3	19.3	25.3	31.3	37.3	13.787
M12X1.5*	12.324	12.560	12.25	12.50	13.80	14.40	12.974	13.067	13.099	13.5	19.5	25.5	31.5	37.5	14.133
M14X1.5*	14.324	14.560	14.25	14.50	15.80	16.40	14.974	15.067	15.099	15.5	22.5	29.5	36.5	43.5	16.131
M16X1.5*	16.324	16.560	16.25	16.50	17.80	18.40	16.974	17.067	17.099	17.5	25.5	33.5	41.5	49.5	18.131
M18X1.5*	18.324	18.560	18.25	18.50	19.80	20.40	18.974	19.067	19.099	19.5	28.5	37.5	46.5	55.5	20.132
M20X1.5*	20.324	20.560	20.25	20.50	21.80	22.40	20.974	21.067	21.099	21.5	31.5	41.5	51.5	61.5	22.131
M22X1.5*	22.324	22.560	22.25	22.50	23.80	24.40	22.974	23.067	23.099	23.5	34.5	45.5	56.5	67.5	24.130
M18X2	18.433	18.733	18.50	18.50	20.50	21.10	19.299	19.406	19.444	20.0	29.0	38.0	47.0	56.0	20.823
M20X2	20.433	20.733	20.50	20.50	22.50	23.10	21.299	21.406	21.444	22.0	32.0	42.0	52.0	62.0	22.822
M22X2	22.433	22.733	22.50	22.50	24.50	25.10	23.299	23.406	23.444	24.0	35.0	46.0	57.0	68.0	24.823
M24X2	24.433	24.733	24.50	24.50	26.50	27.10	25.299	25.414	25.454	26.0	38.0	50.0	62.0	74.0	26.820
M27X2	27.433	27.733	27.50	27.50	29.50	30.10	28.299	28.414	28.455	29.0	42.5	56.0	69.5	83.0	29.822
M30X2	30.433	30.733	30.50	30.50	32.50	33.10	31.299	31.414	31.454	32.0	47.0	62.0	77.0	92.0	32.822
M33X2	33.433	33.733	33.50	33.50	35.50	36.10	34.299	34.414	34.454	35.0	51.5	68.0	84.5	101.0	35.822
M39X2	39.433	39.733	39.50	39.50	41.50	42.10	40.299	40.414	40.454	41.0	60.5	80.0	99.5	119.0	41.821
M36X3	36.649	37.049	37.00	37.00	39.90	40.50	37.948	38.093	38.135	39.0	57.0	75.0	93.0	111.0	40.236
M39X3	39.649	40.049	40.00	40.00	42.90	43.50	40.948	41.093	41.135	42.0	61.5	81.0	100.5	120.0	43.236

* Standard drill diameters have been suggested, although the drilling diameters indicated by MA1567 may be slightly different.

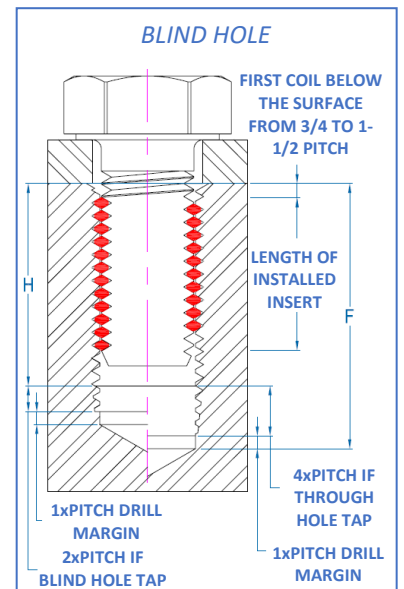
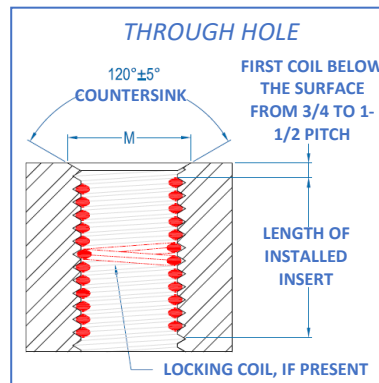

DRILLING – UNC-UNF THREAD

Thread size	Min. diameter (after tapping)			Suggested drill diameter*		Countersink diameter (120° +/-5°)		Mean diameter			Height H Minimum tapping depth					Max Tap Ø	Pitch "P"
	Min	Max 3B	Max 2B	Aluminum	Steel	Min	Max	Min	Max 3B	Max 2B	1d	1.5d	2d	2.5d	3d		
UNC – Coarse thread																	
1 (.073)-64	0.0764	0.0823	0.0823	#47 (.0785)	#46 (.0810)	0.085	0.10	0.0832	0.0843	0.0850	0.09	0.13	0.16	0.20	0.24	0.0958	0.01563
2 (.086)-56	0.0899	0.0961	0.0961	3/32 (.0938)	#41 (.0960)	0.09	0.11	0.0976	0.0989	0.0996	0.10	0.15	0.19	0.23	0.28	0.1117	0.01786
3 (.099)-48	0.1036	0.1104	0.1104	#36 (.1065)	7/64 (.1094)	0.11	0.14	0.1126	0.1140	0.1148	0.12	0.17	0.22	0.27	0.32	0.1289	0.02083
4 (.112)-40	0.1175	0.1252	0.1252	#31 (.1200)	#31 (.1200)	0.14	0.17	0.1283	0.1299	0.1308	0.14	0.19	0.25	0.31	0.36	0.1473	0.02500
5 (.125)-40	0.1305	0.1373	0.1373	3.4mm (.1339)	#29 (.1360)	0.16	0.19	0.1413	0.1430	0.1438	0.15	0.21	0.28	0.34	0.40	0.1603	0.02500
6 (.138)-32	0.1448	0.1527	0.1527	#26 (.1470)	#25 (.1495)	0.18	0.21	0.1583	0.1601	0.1611	0.17	0.24	0.31	0.38	0.45	0.1817	0.03125
8 (.164)-32	0.1708	0.1781	0.1781	#17 (.1730)	#16 (.1770)	0.20	0.23	0.1843	0.1862	0.1872	0.20	0.28	0.36	0.44	0.52	0.2077	0.03125
10 (.190)-24	0.1990	0.2080	0.2087	13/64 (.2031)	#5 (.2055)	0.24	0.27	0.2170	0.2192	0.2203	0.23	0.33	0.42	0.52	0.61	0.2475	0.04167
12 (.216)-24	0.2250	0.2340	0.2347	#1 (.2280)	#1 (.2280)	0.26	0.29	0.2430	0.2453	0.2464	0.26	0.37	0.47	0.58	0.69	0.2735	0.04167
1/4 (.250)-20	0.2608	0.2704	0.2723	H (.2660)	H (.2660)	0.31	0.34	0.2825	0.2851	0.2864	0.30	0.43	0.55	0.68	0.80	0.3187	0.05000
5/16 (.3125)-18	0.3245	0.3342	0.3372	Q (.3320)	Q (.3320)	0.38	0.41	0.3486	0.3515	0.3529	0.37	0.53	0.68	0.84	0.99	0.3884	0.05556
3/8 (.3750)-16	0.3885	0.3987	0.4026	X (.3970)	X (.3970)	0.45	0.48	0.4156	0.4189	0.4203	0.44	0.63	0.81	1.00	1.19	0.4602	0.06250
7/16 (.4375)-14	0.4530	0.4639	0.4688	29/64 (.4531)	29/64 (.4531)	0.52	0.55	0.4839	0.4875	0.4890	0.51	0.73	0.95	1.17	1.38	0.5343	0.07143
1/2 (.5000)-13'	0.5166	0.5273	0.5335	33/64 (.5156)	17/32 (.5312)	0.59	0.62	0.5499	0.5537	0.5554	0.58	0.83	1.08	1.33	1.58	0.6042	0.07692
9/16 (.5625)-12'	0.5806	0.5918	0.5986	37/64 (.5781)	19/32 (.5938)	0.66	0.69	0.6167	0.6208	0.6225	0.65	0.93	1.21	1.49	1.77	0.6751	0.08333
5/8 (.6250)-11	0.6447	0.6564	0.6641	21/32 (.6562)	21/32 (.6562)	0.73	0.76	0.6841	0.6885	0.6903	0.72	1.03	1.34	1.65	1.97	0.7477	0.09091
3/4 (.7500)-10	0.7716	0.7838	0.7926	25/32 (.7812)	25/32 (.7812)	0.87	0.90	0.8149	0.8196	0.8216	0.85	1.23	1.60	1.98	2.35	0.8850	0.10000
7/8 (.8750)-9	0.8990	0.9119	0.9218	29/32 (.9062)	29/32 (.9062)	1.00	1.03	0.9471	0.9522	0.9543	0.99	1.42	1.86	2.30	2.74	1.0247	0.11111
1 (1.0000)-8	1.0271	1.0421	1.0521	1-1/32 (1.0312)	1-1/32 (1.0312)	1.14	1.17	1.0812	1.0898	1.0898	1.13	1.63	2.13	2.63	3.13	1.1681	0.12500
1-1/8 (1.1250)-7	1.1559	1.1730	1.1834	1-11/64 (1.1719)	1-11/64 (1.1719)	1.29	1.32	1.2178	1.2239	1.2262	1.27	1.83	2.39	2.96	3.52	1.3171	0.14286
1-1/4 (1.2500)-7	1.2809	1.2980	1.3084	1-19/64 (1.2969)	1-19/64 (1.2969)	1.41	1.44	1.3428	1.3490	1.3514	1.39	2.02	2.64	3.27	3.89	1.4421	0.14286
1-3/8 (1.3750)-6	1.4110	1.4310	1.4416	1-27/64 (1.4219)	1-27/64 (1.4219)	1.56	1.59	1.4832	1.4900	1.4926	1.54	2.23	2.92	3.60	4.29	1.5982	0.16667
1-1/2 (1.5000)-6	1.5360	1.5560	1.5665	1-35/64 (1.5469)	1-35/64 (1.5469)	1.69	1.72	1.6082	1.6151	1.6177	1.67	2.42	3.17	3.92	4.67	1.7232	0.16667
UNF – Fine thread																	
0 (.060)-80	0.0628	0.0665	0.0665	#52 (.0635)	#52 (.0635)	0.08	0.11	0.0681	0.0691	0.0697	0.07	0.10	0.13	---	---	---	0.01250
3 (.099)-56	0.1029	0.1086	0.1086	#37 (.1040)	#36 (.1065)	0.11	0.14	0.1106	0.1119	0.1126	0.12	0.17	0.22	0.27	0.31	0.1247	0.01786
4 (.112)-48	0.1166	0.1229	0.1229	3mm (.1181)	#31 (.1200)	0.13	0.16	0.1256	0.1271	0.1279	0.13	0.19	0.24	0.30	0.36	0.1419	0.02083
6 (.138)-40	0.1435	0.1503	0.1503	#26 (.1470)	#25 (.1495)	0.17	0.20	0.1543	0.1560	0.1569	0.16	0.23	0.30	0.37	0.44	0.1733	0.02500
8 (.164)-36	0.1701	0.1771	0.1771	#17 (.1730)	#16 (.1770)	0.20	0.23	0.1821	0.1840	0.1849	0.19	0.27	0.36	0.44	0.52	0.2032	0.02778
10 (.190)-32	0.1968	0.2041	0.2041	#7 (.2010)	13/64 (.2031)	0.23	0.26	0.2103	0.2123	0.2133	0.22	0.32	0.41	0.51	0.60	0.2337	0.03125
1/4 (.250)-28	0.2577	0.2646	0.2661	G (.2610)	6.7mm (.2638)	0.29	0.32	0.2732	0.2754	0.2765	0.29	0.41	0.54	0.66	0.79	0.2995	0.03571
5/16 (.3125)-24	0.3215	0.3288	0.3312	21/64 (.3281)	21/64 (.3281)	0.36	0.39	0.3395	0.3421	0.3433	0.35	0.51	0.67	0.82	0.98	0.3700	0.04167
3/8 (.3750)-24	0.3840	0.3910	0.3937	25/64 (.3906)	25/64 (.3906)	0.42	0.45	0.4020	0.4047	0.4059	0.42	0.60	0.79	0.98	1.17	0.4325	0.04167
7/16 (.4375)-20	0.4483	0.4561	0.4598	29/64 (.4531)	29/64 (.4531)	0.50	0.53	0.4700	0.4731	0.4744	0.49	0.71	0.93	1.14	1.36	0.5062	0.05000
1/2 (.5000)-20	0.5108	0.5186	0.5223	33/64 (.5156)	33/64 (.5156)	0.56	0.59	0.5325	0.5357	0.5371	0.55	0.80	1.05	1.30	1.55	0.5687	0.05000
9/16 (.5625)-18	0.5745	0.5826	0.5872	37/64 (.5781)	37/64 (.5781)	0.63	0.66	0.5986	0.6020	0.6035	0.62	0.90	1.18	1.46	1.74	0.6384	0.05556
5/8 (.6250)-18	0.6370	0.6451	0.6497	41/64 (.6406)	41/64 (.6406)	0.69	0.72	0.6611	0.6646	0.6661	0.68	0.99	1.31	1.62	1.93	0.7009	0.05556
3/4 (.7500)-16	0.7635	0.7720	0.7776	49/64 (.7656)	49/64 (.7656)	0.82	0.85	0.7906	0.7945	0.7961	0.81	1.19	1.56	1.94	2.31	0.8352	0.06250
7/8 (.8750)-14	0.8905	0.8994	0.9063	57/64 (.8906)	57/64 (.8906)	0.96	0.99	0.9214	0.9257	0.9274	0.95	1.38	1.82	2.26	2.70	0.9718	0.07143
1 (1.0000)-12	1.0181	1.0281	1.0361	1-1/64 (1.0156)	1-1/32 (1.0312)	1.10	1.13	1.0542	1.0589	1.0608	1.08	1.58	2.08	2.58	3.08	1.1126	0.08333
1-1/8 (1.1250)-12'	1.1431	1.1531	1.1611	1-9/64 (1.1406)	1-5/32 (1.1562)	1.22	1.25	1.1792	1.1841	1.1860	1.21	1.77	2.33	2.90	3.46	1.2376	0.08333
1-1/4 (1.2500)-12'	1.2681	1.2781	1.2861	1-17/64 (1.2656)	1-9/32 (1.2812)	1.35	1.38	1.3042	1.3092	1.3112	1.33	1.96	2.58	3.21	3.83	1.3626	0.08333
1-3/8 (1.3750)-12'	1.3931	1.4031	1.4111	1-25/64 (1.3906)	1-13/32 (1.4062)	1.47	1.50	1.4292	1.4343	1.4364	1.46	2.15	2.83	3.52	4.21	1.4876	0.08333
1-1/2 (1.5000)-12'	1.5181	1.5281	1.5361	1-33/64 (1.5156)	1-17/32 (1.5312)	1.60	1.63	1.5542	1.5595	1.5615	1.58	2.33	3.08	3.83	4.58	1.6126	0.08333

* Standard drill diameters have been suggested, although the drilling diameters indicated by NASM33537 may be slightly different.
All measurements are in inches.

REGULATIONS OF REFERENCE

The "KATO TANGLESS" threaded inserts are fully equivalent and interchangeable with the "classic" threaded inserts with a tang, requiring no changes in thread preparation (same drilling and tapping parameters). They are commonly used in the aerospace field, having been developed for this type of application. The absence of the tang significantly reduces the risks of damage to the screw threads caused by poorly broken tangs or damage to equipment due to tang detachment during assembly or its loss inside the equipment.

The packages are available in quantities of 1000 or 500 pieces, depending on the size, but can be supplied in smaller quantities by always providing the production batch reference number for full traceability.

The inserts are compliant with the following regulations: AS9100B - DFARs - EAR - FAR - ITAR - REACH - RoHS

MILITARY, AEROSPACE, AND COMMERCIAL STANDARDS

The inserts have passed external laboratory tests and have been certified compliant with aerospace specifications NASM8846. In addition, they comply with the following military specifications and standards:

Tanged and Tangless inserts	
	Description
UNC - UNF	
A-A-59158 (MIL-T-21309)	Tools for Inserting and Extracting Helical Coil Inserts
AS7245	Insert, Screw Thread, Helical Coil, CRES, Procurement Specification
AS7246	Insert, Screw Thread, Helical Coil, Corrosion and Heat Resistant Alloy (Inconel), Procurement Spec.
NAS1130	Tangless Inserts, Free-Running and Locking United
NASM122076-122275 (MS122076)	Insert, Screw Thread, Helical Coil, Free Running, Coarse Thread
NASM124651-124850 (MS124651)	Insert, Screw Thread, Helical Coil, Free Running, Fine Thread
NASM21209 (MS21209)	Insert, Screw Thread, Helical Coil, Self-Locking, Coarse and Fine Thread
NASM33537 (MS33537)	Insert, Screw Thread, Helical Coil, Inch Series, Coarse and Fine Thread, Standard Assembly Dims.
NASM8846 (MIL-I-8846)	Insert, Screw Thread, Helical Coil, Unified Series, Procurement Specification
METRIC	
NA0276	Insert, Screw Thread, Helical Coil, Free Running and Self-Locking, Metric, Tangless
MA1565	Insert, Screw Thread, Helical Coil, Metric Series, Procurement Specification
MA1567	Insert, Screw Thread, Helical Coil, Metric Series, Standard Assembly Dims.
MA3279	Insert, Screw Thread, Helical Coil, Free Running, Metric Series, Uncoated
MA3280	Insert, Screw Thread, Helical Coil, Free Running, Metric Series, Dry Film Lubricated
MA3281	Insert, Screw Thread, Helical Coil, Free Running, Metric Series, Cadmium Plated
MA3329	Insert, Screw Thread, Helical Coil, Self-Locking, Metric Series, Uncoated
MA3330	Insert, Screw Thread, Helical Coil, Self-Locking, Metric Series, Dry Film Lubricated
MA3331	Insert, Screw Thread, Helical Coil, Self-Locking, Metric Series, Cadmium Plated
TREATMENTS - COATINGS	
AMS-QQ-P-416	Plating, Cadmium (Electrodeposited)
AMS2410	Plating, Silver, Nickel Strike, High Bake
AMS2411	Plating, Silver for High Temperature Applications
AMS-C-26074	Plating, Electroless Nickel
AMS2700	Passivation of CRES
AS5272 (MIL-L-46010)	Lubricant, Solid Film, Heat Cured, Corrosion Inhibiting, Procurement Specification

* Regulation MS21208 has been surpassed by MS122076 & MS124651, and subsequently surpassed by the NASM122076 & NASM124651.

Special Note: In 1998-1999, the military standard "Military Standard" (MS) for Unified Size threaded fasteners was surpassed by the "National Aerospace Standard" (NAS) with an "M" suffix indicating the previous affiliation with a military standard.



Tangless code	MA/NAS	MS (Equivalent)	Tangless code	MA/NAS	MS (Equivalent)*	Tangless code	MA/NAS	MS (Equivalent)*
UNC - Unified Coarse								
2TLC-01C-0073	N/A	N/A	N/A	N/A	N/A	N/A	N/A	N/A
2TLC-01C-0110	N/A	N/A	N/A	N/A	N/A	N/A	N/A	N/A
2TLC-01C-0146	N/A	N/A	N/A	N/A	N/A	N/A	N/A	N/A
2TNC-02C-0086	NAS1130-02-10	MS122095	2TNC-02C-0086W	NAS1130-02-10D	MS122095-MOD	2TNC-02C-0086Y	NAS1130-02-10P	MS122095-MOD
2TNC-02C-0129	NAS1130-02-15	MS122135	2TNC-02C-0129W	NAS1130-02-15D	MS122135-MOD	2TNC-02C-0129Y	NAS1130-02-15P	MS122135-MOD
2TNC-02C-0172	NAS1130-02-20	MS122175	2TNC-02C-0172W	NAS1130-02-20D	MS122175-MOD	2TNC-02C-0172Y	NAS1130-02-20P	MS122175-MOD
2TNC-02C-0215	NAS1130-02-25	MS122215	2TNC-02C-0215W	NAS1130-02-25D	MS122215-MOD	2TNC-02C-0215Y	NAS1130-02-25P	MS122215-MOD
2TNC-02C-0258	NAS1130-02-30	MS122255	2TNC-02C-0258W	NAS1130-02-30D	MS122255-MOD	2TNC-02C-0258Y	NAS1130-02-30P	MS122255-MOD
2TNC-04C-0112	NAS1130-04-10	MS122076	2TNC-04C-0112W	NAS1130-04-10D	MS122076-MOD	2TNC-04C-0112Y	NAS1130-04-10P	MS122076-MOD
2TNC-04C-0168	NAS1130-04-15	MS122116	2TNC-04C-0168W	NAS1130-04-15D	MS122116-MOD	2TNC-04C-0168Y	NAS1130-04-15P	MS122116-MOD
2TNC-04C-0224	NAS1130-04-20	MS122156	2TNC-04C-0224W	NAS1130-04-20D	MS122156-MOD	2TNC-04C-0224Y	NAS1130-04-20P	MS122156-MOD
2TNC-04C-0280	NAS1130-04-25	MS122196	2TNC-04C-0280W	NAS1130-04-25D	MS122196-MOD	2TNC-04C-0280Y	NAS1130-04-25P	MS122196-MOD
2TNC-04C-0336	NAS1130-04-30	MS122236	2TNC-04C-0336W	NAS1130-04-30D	MS122236-MOD	2TNC-04C-0336Y	NAS1130-04-30P	MS122236-MOD
2TNC-06C-0138	NAS1130-06-10	MS122078	2TNC-06C-0138W	NAS1130-06-10D	MS122078-MOD	2TNC-06C-0138Y	NAS1130-06-10P	MS122078-MOD
2TNC-06C-0207	NAS1130-06-15	MS122118	2TNC-06C-0207W	NAS1130-06-15D	MS122118-MOD	2TNC-06C-0207Y	NAS1130-06-15P	MS122118-MOD
2TNC-06C-0276	NAS1130-06-20	MS122158	2TNC-06C-0276W	NAS1130-06-20D	MS122158-MOD	2TNC-06C-0276Y	NAS1130-06-20P	MS122158-MOD
2TNC-06C-0345	NAS1130-06-25	MS122198	2TNC-06C-0345W	NAS1130-06-25D	MS122198-MOD	2TNC-06C-0345Y	NAS1130-06-25P	MS122198-MOD
2TNC-06C-0414	NAS1130-06-30	MS122238	2TNC-06C-0414W	NAS1130-06-30D	MS122238-MOD	2TNC-06C-0414Y	NAS1130-06-30P	MS122238-MOD
2TNC-2C-0164	NAS1130-08-10	MS122079	2TNC-2C-0164W	NAS1130-08-10D	MS122079-MOD	2TNC-2C-0164Y	NAS1130-08-10P	MS122079-MOD
2TNC-2C-0246	NAS1130-08-15	MS122119	2TNC-2C-0246W	NAS1130-08-15D	MS122119-MOD	2TNC-2C-0246Y	NAS1130-08-15P	MS122119-MOD
2TNC-2C-0328	NAS1130-08-20	MS122159	2TNC-2C-0328W	NAS1130-08-20D	MS122159-MOD	2TNC-2C-0328Y	NAS1130-08-20P	MS122159-MOD
2TNC-2C-0410	NAS1130-08-25	MS122199	2TNC-2C-0410W	NAS1130-08-25D	MS122199-MOD	2TNC-2C-0410Y	NAS1130-08-25P	MS122199-MOD
2TNC-2C-0492	NAS1130-08-30	MS122239	2TNC-2C-0492W	NAS1130-08-30D	MS122239-MOD	2TNC-2C-0492Y	NAS1130-08-30P	MS122239-MOD
2TNC-3C-0190	NAS1130-3C-10	MS122080	2TNC-3C-0190W	NAS1130-3C-10D	MS122080-MOD	2TNC-3C-0190Y	NAS1130-3C-10P	MS122080-MOD
2TNC-3C-0285	NAS1130-3C-15	MS122120	2TNC-3C-0285W	NAS1130-3C-15D	MS122120-MOD	2TNC-3C-0285Y	NAS1130-3C-15P	MS122120-MOD
2TNC-3C-0380	NAS1130-3C-20	MS122160	2TNC-3C-0380W	NAS1130-3C-20D	MS122160-MOD	2TNC-3C-0380Y	NAS1130-3C-20P	MS122160-MOD
2TNC-3C-0475	NAS1130-3C-25	MS122200	2TNC-3C-0475W	NAS1130-3C-25D	MS122200-MOD	2TNC-3C-0475Y	NAS1130-3C-25P	MS122200-MOD
2TNC-3C-0570	NAS1130-3C-30	MS122240	2TNC-3C-0570W	NAS1130-3C-30D	MS122240-MOD	2TNC-3C-0570Y	NAS1130-3C-30P	MS122240-MOD
2TNC-4C-0250	NAS1130-4-10	MS122081	2TNC-4C-0250W	NAS1130-4-10D	MS122081-MOD	2TNC-4C-0250Y	NAS1130-4-10P	MS122081-MOD
2TNC-4C-0375	NAS1130-4-15	MS122121	2TNC-4C-0375W	NAS1130-4-15D	MS122121-MOD	2TNC-4C-0375Y	NAS1130-4-15P	MS122121-MOD
2TNC-4C-0500	NAS1130-4-20	MS122161	2TNC-4C-0500W	NAS1130-4-20D	MS122161-MOD	2TNC-4C-0500Y	NAS1130-4-20P	MS122161-MOD
2TNC-4C-0625	NAS1130-4-25	MS122201	2TNC-4C-0625W	NAS1130-4-25D	MS122201-MOD	2TNC-4C-0625Y	NAS1130-4-25P	MS122201-MOD
2TNC-4C-0750	NAS1130-4-30	MS122241	2TNC-4C-0750W	NAS1130-4-30D	MS122241-MOD	2TNC-4C-0750Y	NAS1130-4-30P	MS122241-MOD
2TNC-5C-0312	NAS1130-5C-10	MS122082	2TNC-5C-0312W	NAS1130-5C-10D	MS122082-MOD	2TNC-5C-0312Y	NAS1130-5C-10P	MS122082-MOD
2TNC-5C-0469	NAS1130-5C-15	MS122122	2TNC-5C-0469W	NAS1130-5C-15D	MS122122-MOD	2TNC-5C-0469Y	NAS1130-5C-15P	MS122122-MOD
2TNC-5C-0625	NAS1130-5C-20	MS122162	2TNC-5C-0625W	NAS1130-5C-20D	MS122162-MOD	2TNC-5C-0625Y	NAS1130-5C-20P	MS122162-MOD
2TNC-5C-0781	NAS1130-5C-25	MS122202	2TNC-5C-0781W	NAS1130-5C-25D	MS122202-MOD	2TNC-5C-0781Y	NAS1130-5C-25P	MS122202-MOD
2TNC-5C-0938	NAS1130-5C-30	MS122242	2TNC-5C-0938W	NAS1130-5C-30D	MS122242-MOD	2TNC-5C-0938Y	NAS1130-5C-30P	MS122242-MOD
2TNC-6C-0375	NAS1130-6C-10	MS122083	2TNC-6C-0375W	NAS1130-6C-10D	MS122083-MOD	2TNC-6C-0375Y	NAS1130-6C-10P	MS122083-MOD
2TNC-6C-0562	NAS1130-6C-15	MS122123	2TNC-6C-0562W	NAS1130-6C-15D	MS122123-MOD	2TNC-6C-0562Y	NAS1130-6C-15P	MS122123-MOD
2TNC-6C-0750	NAS1130-6C-20	MS122163	2TNC-6C-0750W	NAS1130-6C-20D	MS122163-MOD	2TNC-6C-0750Y	NAS1130-6C-20P	MS122163-MOD
2TNC-6C-0938	NAS1130-6C-25	MS122203	2TNC-6C-0938W	NAS1130-6C-25D	MS122203-MOD	2TNC-6C-0938Y	NAS1130-6C-25P	MS122203-MOD
UNF - Unified Fine								
2TNF-00C-0060	N/A	N/A	N/A	N/A	N/A	N/A	N/A	N/A
2TNF-00C-0090	N/A	N/A	N/A	N/A	N/A	N/A	N/A	N/A
2TNF-00C-0120	N/A	N/A	N/A	N/A	N/A	N/A	N/A	N/A
2TNF-3C-0190	NAS1130-3-10	MS124655	2TNF-3C-0190W	NAS1130-3-10D	MS124655-MOD	2TNF-3C-0190Y	NAS1130-3-10P	MS124655-MOD
2TNF-3C-0285	NAS1130-3-15	MS124695	2TNF-3C-0285W	NAS1130-3-15D	MS124695-MOD	2TNF-3C-0285Y	NAS1130-3-15P	MS124695-MOD
2TNF-3C-0380	NAS1130-3-20	MS124735	2TNF-3C-0380W	NAS1130-3-20D	MS124735-MOD	2TNF-3C-0380Y	NAS1130-3-20P	MS124735-MOD
2TNF-3C-0475	NAS1130-3-25	MS124775	2TNF-3C-0475W	NAS1130-3-25D	MS124775-MOD	2TNF-3C-0475Y	NAS1130-3-25P	MS124775-MOD
2TNF-3C-0570	NAS1130-3-30	MS124815	2TNF-3C-0570W	NAS1130-3-30D	MS124815-MOD	2TNF-3C-0570Y	NAS1130-3-30P	MS124815-MOD
2TNF-4C-0250	NAS1130-4F-10	MS124656	2TNF-4C-0250W	NAS1130-4F-10D	MS124656-MOD	2TNF-4C-0250Y	NAS1130-4F-10P	MS124656-MOD
2TNF-4C-0375	NAS1130-4F-15	MS124696	2TNF-4C-0375W	NAS1130-4F-15D	MS124696-MOD	2TNF-4C-0375Y	NAS1130-4F-15P	MS124696-MOD
2TNF-4C-0500	NAS1130-4F-20	MS124736	2TNF-4C-0500W	NAS1130-4F-20D	MS124736-MOD	2TNF-4C-0500Y	NAS1130-4F-20P	MS124736-MOD
2TNF-4C-0625	NAS1130-4F-25	MS124776	2TNF-4C-0625W	NAS1130-4F-25D	MS124776-MOD	2TNF-4C-0625Y	NAS1130-4F-25P	MS124776-MOD
2TNF-4C-0750	NAS1130-4F-30	MS124816	2TNF-4C-0750W	NAS1130-4F-30D	MS124816-MOD	2TNF-4C-0750Y	NAS1130-4F-30P	MS124816-MOD
2TNF-5C-0312	NAS1130-5F-10	MS124657	2TNF-5C-0312W	NAS1130-5F-10D	MS124657-MOD	2TNF-5C-0312Y	NAS1130-5F-10P	MS124657-MOD
2TNF-5C-0469	NAS1130-5F-15	MS124697	2TNF-5C-0469W	NAS1130-5F-15D	MS124697-MOD	2TNF-5C-0469Y	NAS1130-5F-15P	MS124697-MOD
2TNF-5C-0625	NAS1130-5F-20	MS124737	2TNF-5C-0625W	NAS1130-5F-20D	MS124737-MOD	2TNF-5C-0625Y	NAS1130-5F-20P	MS124737-MOD
2TNF-5C-0781	NAS1130-5F-25	MS124777	2TNF-5C-0781W	NAS1130-5F-25D	MS124777-MOD	2TNF-5C-0781Y	NAS1130-5F-25P	MS124777-MOD
2TNF-6C-0375	NAS1130-6F-10	MS124658	2TNF-6C-0375W	NAS1130-6F-10D	MS124658-MOD	2TNF-6C-0375Y	NAS1130-6F-10P	MS124658-MOD
2TNF-6C-0562	NAS1130-6F-15	MS124698	2TNF-6C-0562W	NAS1130-6F-15D	MS124698-MOD	2TNF-6C-0562Y	NAS1130-6F-15P	MS124698-MOD
2TNF-6C-0750	NAS1130-6F-20	MS124738	2TNF-6C-0750W	NAS1130-6F-20D	MS124738-MOD	2TNF-6C-0750Y	NAS1130-6F-20P	MS124738-MOD



Tangless code	MA/NAS	MS (Equivalent)	Tangless code	MA/NAS	MS (Equivalent)*	Tangless code	MA/NAS	MS (Equivalent)*
Metric								
2TNM-2X.4C-2	N/A	MA3279-140	2TNM-2X.4C-2W	N/A	MA3280-140	2TNM-2X.4C-2Y	N/A	MA3281-140
2TNM-2X.4C-3	N/A	MA3279-190	2TNM-2X.4C-3W	N/A	MA3280-190	2TNM-2X.4C-3Y	N/A	MA3281-190
2TNM-2X.4C-4	N/A	MA3279-240	2TNM-2X.4C-4W	N/A	MA3280-240	2TNM-2X.4C-4Y	N/A	MA3281-240
2TNM-2.5X.45C-2.5	NA0276M2A-10	MA3279-101	2TNM-2.5X.45C-2.5W	NA0276M2A-10D	MA3280-101	2TNM-2.5X.45C-2.5Y	NA0276M2A-10P	MA3281-101
2TNM-2.5X.45C-3.8	NA0276M2A-15	MA3279-151	2TNM-2.5X.45C-3.8W	NA0276M2A-15D	MA3280-151	2TNM-2.5X.45C-3.8Y	NA0276M2A-15P	MA3281-151
2TNM-2.5X.45C-5	NA0276M2A-20	MA3279-201	2TNM-2.5X.45C-5W	NA0276M2A-20D	MA3280-201	2TNM-2.5X.45C-5Y	NA0276M2A-20P	MA3281-201
2TNM-2.5X.45C-6.3	NA0276M2A-25	MA3279-251	2TNM-2.5X.45C-6.3W	NA0276M2A-25D	MA3280-251	2TNM-2.5X.45C-6.3Y	NA0276M2A-25P	MA3281-251
2TNM-2.5X.45C-7.5	NA0276M2A-30	MA3279-301	2TNM-2.5X.45C-7.5W	NA0276M2A-30D	MA3280-301	2TNM-2.5X.45C-7.5Y	NA0276M2A-30P	MA3281-301
2TNM-3X.5C-3	NA0276M3-10	MA3279-102	2TNM-3X.5C-3W	NA0276M3-10D	MA3280-102	2TNM-3X.5C-3Y	NA0276M3-10P	MA3281-102
2TNM-3X.5C-4.5	NA0276M3-15	MA3279-152	2TNM-3X.5C-4.5W	NA0276M3-15D	MA3280-152	2TNM-3X.5C-4.5Y	NA0276M3-15P	MA3281-152
2TNM-3X.5C-6	NA0276M3-20	MA3279-202	2TNM-3X.5C-6W	NA0276M3-20D	MA3280-202	2TNM-3X.5C-6Y	NA0276M3-20P	MA3281-202
2TNM-3X.5C-7.5	NA0276M3-25	MA3279-252	2TNM-3X.5C-7.5W	NA0276M3-25D	MA3280-252	2TNM-3X.5C-7.5Y	NA0276M3-25P	MA3281-252
2TNM-3X.5C-9	NA0276M3-30	MA3279-302	2TNM-3X.5C-9W	NA0276M3-30D	MA3280-302	2TNM-3X.5C-9Y	NA0276M3-30P	MA3281-302
2TNM-4X.7C-4	NA0276M4-10	MA3279-104	2TNM-4X.7C-4W	NA0276M4-10D	MA3280-104	2TNM-4X.7C-4Y	NA0276M4-10P	MA3281-104
2TNM-4X.7C-6	NA0276M4-15	MA3279-154	2TNM-4X.7C-6W	NA0276M4-15D	MA3280-154	2TNM-4X.7C-6Y	NA0276M4-15P	MA3281-154
2TNM-4X.7C-8	NA0276M4-20	MA3279-204	2TNM-4X.7C-8W	NA0276M4-20D	MA3280-204	2TNM-4X.7C-8Y	NA0276M4-20P	MA3281-204
2TNM-4X.7C-10	NA0276M4-25	MA3279-254	2TNM-4X.7C-10W	NA0276M4-25D	MA3280-254	2TNM-4X.7C-10Y	NA0276M4-25P	MA3281-254
2TNM-4X.7C-12	NA0276M4-30	MA3279-304	2TNM-4X.7C-12W	NA0276M4-30D	MA3280-304	2TNM-4X.7C-12Y	NA0276M4-30P	MA3281-304
2TNM-5X.8C-5	NA0276M5-10	MA3279-105	2TNM-5X.8C-5W	NA0276M5-10D	MA3280-105	2TNM-5X.8C-5Y	NA0276M5-10P	MA3281-105
2TNM-5X.8C-7.5	NA0276M5-15	MA3279-155	2TNM-5X.8C-7.5W	NA0276M5-15D	MA3280-155	2TNM-5X.8C-7.5Y	NA0276M5-15P	MA3281-155
2TNM-5X.8C-10	NA0276M5-20	MA3279-205	2TNM-5X.8C-10W	NA0276M5-20D	MA3280-205	2TNM-5X.8C-10Y	NA0276M5-20P	MA3281-205
2TNM-5X.8C-12.5	NA0276M5-25	MA3279-255	2TNM-5X.8C-12.5W	NA0276M5-25D	MA3280-255	2TNM-5X.8C-12.5Y	NA0276M5-25P	MA3281-255
2TNM-5X.8C-15	NA0276M5-30	MA3279-305	2TNM-5X.8C-15W	NA0276M5-30D	MA3280-305	2TNM-5X.8C-15Y	NA0276M5-30P	MA3281-305
2TNM-6X1C-6	NA0276M6-10	MA3279-106	2TNM-6X1C-6W	NA0276M6-10D	MA3280-106	2TNM-6X1C-6Y	NA0276M6-10P	MA3281-106
2TNM-6X1C-9	NA0276M6-15	MA3279-156	2TNM-6X1C-9W	NA0276M6-15D	MA3280-156	2TNM-6X1C-9Y	NA0276M6-15P	MA3281-156
2TNM-6X1C-12	NA0276M6-20	MA3279-206	2TNM-6X1C-12W	NA0276M6-20D	MA3280-206	2TNM-6X1C-12Y	NA0276M6-20P	MA3281-206
2TNM-6X1C-15	NA0276M6-25	MA3279-256	2TNM-6X1C-15W	NA0276M6-25D	MA3280-256	2TNM-6X1C-15Y	NA0276M6-25P	MA3281-256
2TNM-6X1C-18	NA0276M6-30	MA3279-306	2TNM-6X1C-18W	NA0276M6-30D	MA3280-306	2TNM-6X1C-18Y	NA0276M6-30P	MA3281-306
2TNM-8X1.25C-8	NA0276M8-10	MA3279-109	2TNM-8X1.25C-8W	NA0276M8-10D	MA3280-109	2TNM-8X1.25C-8Y	NA0276M8-10P	MA3281-109
2TNM-8X1.25C-12	NA0276M8-15	MA3279-159	2TNM-8X1.25C-12W	NA0276M8-15D	MA3280-159	2TNM-8X1.25C-12Y	NA0276M8-15P	MA3281-159
2TNM-8X1.25C-16	NA0276M8-20	MA3279-209	2TNM-8X1.25C-16W	NA0276M8-20D	MA3280-209	2TNM-8X1.25C-16Y	NA0276M8-20P	MA3281-209
2TNM-8X1.25C-20	NA0276M8-25	MA3279-259	2TNM-8X1.25C-20W	NA0276M8-25D	MA3280-259	2TNM-8X1.25C-20Y	NA0276M8-25P	MA3281-259
2TNM-8X1.25C-24	NA0276M8-30	MA3279-309	2TNM-8X1.25C-24W	NA0276M8-30D	MA3280-309	2TNM-8X1.25C-24Y	NA0276M8-30P	MA3281-309
2TNM-10X1.5C-10	NA0276M10-10	MA3279-111	2TNM-10X1.5C-10W	NA0276M10-10D	MA3280-111	2TNM-10X1.5C-10Y	NA0276M10-10P	MA3281-111
2TNM-10X1.5C-15	NA0276M10-15	MA3279-161	2TNM-10X1.5C-15W	NA0276M10-15D	MA3280-161	2TNM-10X1.5C-15Y	NA0276M10-15P	MA3281-161
2TNM-10X1.5C-20	NA0276M10-20	MA3279-211	2TNM-10X1.5C-20W	NA0276M10-20D	MA3280-211	2TNM-10X1.5C-20Y	NA0276M10-20P	MA3281-211
2TNM-10X1.5C-25	NA0276M10-25	MA3279-261	2TNM-10X1.5C-24W	NA0276M10-25D	MA3280-261	2TNM-10X1.5C-25Y	NA0276M10-25P	MA3281-261
2TNM-12X1.75C-12	NA0276M12-10	MA3279-114	2TNM-12X1.75C-12W	NA0276M12-10D	MA3280-114	2TNM-12X1.75C-12Y	NA0276M12-10P	MA3281-114
2TNM-12X1.75C-18	NA0276M12-15	MA3279-164	2TNM-12X1.75C-18W	NA0276M12-15D	MA3280-164	2TNM-12X1.75C-18Y	NA0276M12-15P	MA3281-164
2TNM-12X1.75C-24	NA0276M12-20	MA3279-214	2TNM-12X1.75C-24W	NA0276M12-20D	MA3280-214	2TNM-12X1.75C-24Y	NA0276M12-20P	MA3281-214



Tangless code	MA/NAS	MS (Equivalent)	Tangless code	MA/NAS	MS (Equivalent)	Tangless code	MA/NAS	MS (Equivalent)
UNC - Unified Coarse								
2TLC-01C-0073	N/A	N/A	N/A	N/A	N/A	N/A	N/A	N/A
2TLC-01C-0110	N/A	N/A	N/A	N/A	N/A	N/A	N/A	N/A
2TLC-01C-0146	N/A	N/A	N/A	N/A	N/A	N/A	N/A	N/A
2TLC-02C-0086	NAS1130-02L10	MS21209C0210	2TLC-02C-0086W	NAS1130-02L10D	MS21209C0210L	2TLC-02C-0086Y	NAS1130-02L10P	MS21209C0210P
2TLC-02C-0129	NAS1130-02L15	MS21209C0215	2TLC-02C-0129W	NAS1130-02L15D	MS21209C0215L	2TLC-02C-0129Y	NAS1130-02L15P	MS21209C0215P
2TLC-02C-0172	NAS1130-02L20	MS21209C0220	2TLC-02C-0172W	NAS1130-02L20D	MS21209C0220L	2TLC-02C-0172Y	NAS1130-02L20P	MS21209C0220P
2TLC-02C-0215	NAS1130-02L25	MS21209C0225	2TLC-02C-0215W	NAS1130-02L25D	MS21209C0225L	2TLC-02C-0215Y	NAS1130-02L25P	MS21209C0225P
2TLC-02C-0258	NAS1130-02L30	MS21209C0230	2TLC-02C-0258W	NAS1130-02L30D	MS21209C0230L	2TLC-02C-0258Y	NAS1130-02L30P	MS21209C0230P
2TLC-04C-0112	NAS1130-04L10	MS21209C0410	2TLC-04C-0112W	NAS1130-04L10D	MS21209C0410L	2TLC-04C-0112Y	NAS1130-04L10P	MS21209C0410P
2TLC-04C-0168	NAS1130-04L15	MS21209C0415	2TLC-04C-0168W	NAS1130-04L15D	MS21209C0415L	2TLC-04C-0168Y	NAS1130-04L15P	MS21209C0415P
2TLC-04C-0224	NAS1130-04L20	MS21209C0420	2TLC-04C-0224W	NAS1130-04L20D	MS21209C0420L	2TLC-04C-0224Y	NAS1130-04L20P	MS21209C0420P
2TLC-04C-0280	NAS1130-04L25	MS21209C0425	2TLC-04C-0280W	NAS1130-04L25D	MS21209C0425L	2TLC-04C-0280Y	NAS1130-04L25P	MS21209C0425P
2TLC-04C-0336	NAS1130-04L30	MS21209C0430	2TLC-04C-0336W	NAS1130-04L30D	MS21209C0430L	2TLC-04C-0336Y	NAS1130-04L30P	MS21209C0430P
2TLC-06C-0138	NAS1130-06L10	MS21209C0610	2TLC-06C-0138W	NAS1130-06L10D	MS21209C0610L	2TLC-06C-0138Y	NAS1130-06L10P	MS21209C0610P
2TLC-06C-0207	NAS1130-06L15	MS21209C0615	2TLC-06C-0207W	NAS1130-06L15D	MS21209C0615L	2TLC-06C-0207Y	NAS1130-06L15P	MS21209C0615P
2TLC-06C-0276	NAS1130-06L20	MS21209C0620	2TLC-06C-0276W	NAS1130-06L20D	MS21209C0620L	2TLC-06C-0276Y	NAS1130-06L20P	MS21209C0620P
2TLC-06C-0345	NAS1130-06L25	MS21209C0625	2TLC-06C-0345W	NAS1130-06L25D	MS21209C0625L	2TLC-06C-0345Y	NAS1130-06L25P	MS21209C0625P
2TLC-06C-0414	NAS1130-06L30	MS21209C0630	2TLC-06C-0414W	NAS1130-06L30D	MS21209C0630L	2TLC-06C-0414Y	NAS1130-06L30P	MS21209C0630P
2TLC-2C-0164	NAS1130-08L10	MS21209C0810	2TLC-2C-0164W	NAS1130-08L10D	MS21209C0810L	2TLC-2C-0164Y	NAS1130-08L10P	MS21209C0810P
2TLC-2C-0246	NAS1130-08L15	MS21209C0815	2TLC-2C-0246W	NAS1130-08L15D	MS21209C0815L	2TLC-2C-0246Y	NAS1130-08L15P	MS21209C0815P
2TLC-2C-0328	NAS1130-08L20	MS21209C0820	2TLC-2C-0328W	NAS1130-08L20D	MS21209C0820L	2TLC-2C-0328Y	NAS1130-08L20P	MS21209C0820P
2TLC-2C-0410	NAS1130-08L25	MS21209C0825	2TLC-2C-0410W	NAS1130-08L25D	MS21209C0825L	2TLC-2C-0410Y	NAS1130-08L25P	MS21209C0825P
2TLC-2C-0492	NAS1130-08L30	MS21209C0830	2TLC-2C-0492W	NAS1130-08L30D	MS21209C0830L	2TLC-2C-0492Y	NAS1130-08L30P	MS21209C0830P
2TLC-3C-0190	NAS1130-3CL10	MS21209C1-10	2TLC-3C-0190W	NAS1130-3CL10D	MS21209C1-10L	2TLC-3C-0190Y	NAS1130-3CL10P	MS21209C1-10P
2TLC-3C-0285	NAS1130-3CL15	MS21209C1-15	2TLC-3C-0285W	NAS1130-3CL15D	MS21209C1-15L	2TLC-3C-0285Y	NAS1130-3CL15P	MS21209C1-15P
2TLC-3C-0380	NAS1130-3CL20	MS21209C1-20	2TLC-3C-0380W	NAS1130-3CL20D	MS21209C1-20L	2TLC-3C-0380Y	NAS1130-3CL20P	MS21209C1-20P
2TLC-3C-0475	NAS1130-3CL25	MS21209C1-25	2TLC-3C-0475W	NAS1130-3CL25D	MS21209C1-25L	2TLC-3C-0475Y	NAS1130-3CL25P	MS21209C1-25P
2TLC-3C-0570	NAS1130-3CL30	MS21209C1-30	2TLC-3C-0570W	NAS1130-3CL30D	MS21209C1-30L	2TLC-3C-0570Y	NAS1130-3CL30P	MS21209C1-30P
2TLC-4C-0250	NAS1130-4L10	MS21209C4-10	2TLC-4C-0250W	NAS1130-4L10D	MS21209C4-10L	2TLC-4C-0250Y	NAS1130-4L10P	MS21209C4-10P
2TLC-4C-0375	NAS1130-4L15	MS21209C4-15	2TLC-4C-0375W	NAS1130-4L15D	MS21209C4-15L	2TLC-4C-0375Y	NAS1130-4L15P	MS21209C4-15P
2TLC-4C-0500	NAS1130-4L20	MS21209C4-20	2TLC-4C-0500W	NAS1130-4L20D	MS21209C4-20L	2TLC-4C-0500Y	NAS1130-4L20P	MS21209C4-20P
2TLC-4C-0625	NAS1130-4L25	MS21209C4-25	2TLC-4C-0625W	NAS1130-4L25D	MS21209C4-25L	2TLC-4C-0625Y	NAS1130-4L25P	MS21209C4-25P
2TLC-4C-0750	NAS1130-4L30	MS21209C4-30	2TLC-4C-0750W	NAS1130-4L30D	MS21209C4-30L	2TLC-4C-0750Y	NAS1130-4L30P	MS21209C4-30P
2TLC-5C-0312	NAS1130-5L10	MS21209C5-10	2TLC-5C-0312W	NAS1130-5L10D	MS21209C5-10L	2TLC-5C-0312Y	NAS1130-5L10P	MS21209C5-10P
2TLC-5C-0469	NAS1130-5L15	MS21209C5-15	2TLC-5C-0469W	NAS1130-5L15D	MS21209C5-15L	2TLC-5C-0469Y	NAS1130-5L15P	MS21209C5-15P
2TLC-5C-0625	NAS1130-5L20	MS21209C5-20	2TLC-5C-0625W	NAS1130-5L20D	MS21209C5-20L	2TLC-5C-0625Y	NAS1130-5L20P	MS21209C5-20P
2TLC-5C-0781	NAS1130-5L25	MS21209C5-25	2TLC-5C-0781W	NAS1130-5L25D	MS21209C5-25L	2TLC-5C-0781Y	NAS1130-5L25P	MS21209C5-25P
2TLC-5C-0938	NAS1130-5L30	MS21209C5-30	2TLC-5C-0938W	NAS1130-5L30D	MS21209C5-30L	2TLC-5C-0938Y	NAS1130-5L30P	MS21209C5-30P
2TLC-6C-0375	NAS1130-6L10	MS21209C6-10	2TLC-6C-0375W	NAS1130-6L10D	MS21209C6-10L	2TLC-6C-0375Y	NAS1130-6L10P	MS21209C6-10P
2TLC-6C-0562	NAS1130-6L15	MS21209C6-15	2TLC-6C-0562W	NAS1130-6L15D	MS21209C6-15L	2TLC-6C-0562Y	NAS1130-6L15P	MS21209C6-15P
2TLC-6C-0750	NAS1130-6L20	MS21209C6-20	2TLC-6C-0750W	NAS1130-6L20D	MS21209C6-20L	2TLC-6C-0750Y	NAS1130-6L20P	MS21209C6-20P
2TLC-6C-0938	NAS1130-6L25	MS21209C6-25	2TLC-6C-0938W	NAS1130-6L25D	MS21209C6-25L	2TLC-6C-0938Y	NAS1130-6L25P	MS21209C6-25P
UNF - Unified Fine								
2TLF-3C-0190	NAS1130-3L10	MS21209F1-10	2TLF-3C-0190W	NAS1130-3L10D	MS21209F1-10L	2TLF-3C-0190Y	NAS1130-3L10P	MS21209F1-10P
2TLF-3C-0285	NAS1130-3L15	MS21209F1-15	2TLF-3C-0285W	NAS1130-3L15D	MS21209F1-15L	2TLF-3C-0285Y	NAS1130-3L15P	MS21209F1-15P
2TLF-3C-0380	NAS1130-3L20	MS21209F1-20	2TLF-3C-0380W	NAS1130-3L20D	MS21209F1-20L	2TLF-3C-0380Y	NAS1130-3L20P	MS21209F1-20P
2TLF-3C-0475	NAS1130-3L25	MS21209F1-25	2TLF-3C-0475W	NAS1130-3L25D	MS21209F1-25L	2TLF-3C-0475Y	NAS1130-3L25P	MS21209F1-25P
2TLF-3C-0570	NAS1130-3L30	MS21209F1-30	2TLF-3C-0570W	NAS1130-3L30D	MS21209F1-30L	2TLF-3C-0570Y	NAS1130-3L30P	MS21209F1-30P
2TLF-4C-0250	NAS1130-4FL10	MS21209F4-10	2TLF-4C-0250W	NAS1130-4FL10D	MS21209F4-10L	2TLF-4C-0250Y	NAS1130-4FL10P	MS21209F4-10P
2TLF-4C-0375	NAS1130-4FL15	MS21209F4-15	2TLF-4C-0375W	NAS1130-4FL15D	MS21209F4-15L	2TLF-4C-0375Y	NAS1130-4FL15P	MS21209F4-15P
2TLF-4C-0500	NAS1130-4FL20	MS21209F4-20	2TLF-4C-0500W	NAS1130-4FL20D	MS21209F4-20L	2TLF-4C-0500Y	NAS1130-4FL20P	MS21209F4-20P
2TLF-4C-0625	NAS1130-4FL25	MS21209F4-25	2TLF-4C-0625W	NAS1130-4FL25D	MS21209F4-25L	2TLF-4C-0625Y	NAS1130-4FL25P	MS21209F4-25P
2TLF-4C-0750	NAS1130-4FL30	MS21209F4-30	2TLF-4C-0750W	NAS1130-4FL30D	MS21209F4-30L	2TLF-4C-0750Y	NAS1130-4FL30P	MS21209F4-30P
2TLF-5C-0312	NAS1130-5FL10	MS21209F5-10	2TLF-5C-0312W	NAS1130-5FL10D	MS21209F5-10L	2TLF-5C-0312Y	NAS1130-5FL10P	MS21209F5-10P
2TLF-5C-0469	NAS1130-5FL15	MS21209F5-15	2TLF-5C-0469W	NAS1130-5FL15D	MS21209F5-15L	2TLF-5C-0469Y	NAS1130-5FL15P	MS21209F5-15P
2TLF-5C-0625	NAS1130-5FL20	MS21209F5-20	2TLF-5C-0625W	NAS1130-5FL20D	MS21209F5-20L	2TLF-5C-0625Y	NAS1130-5FL20P	MS21209F5-20P
2TLF-5C-0781	NAS1130-5FL25	MS21209F5-25	2TLF-5C-0781W	NAS1130-5FL25D	MS21209F5-25L	2TLF-5C-0781Y	NAS1130-5FL25P	MS21209F5-25P
2TLF-6C-0375	NAS1130-6FL10	MS21209F6-10	2TLF-6C-0375W	NAS1130-6FL10D	MS21209F6-10L	2TLF-6C-0375Y	NAS1130-6FL10P	MS21209F6-10P
2TLF-6C-0562	NAS1130-6FL15	MS21209F6-15	2TLF-6C-0562W	NAS1130-6FL15D	MS21209F6-15L	2TLF-6C-0562Y	NAS1130-6FL15P	MS21209F6-15P
2TLF-6C-0750	NAS1130-6FL20	MS21209F6-20	2TLF-6C-0750W	NAS1130-6FL20D	MS21209F6-20L	2TLF-6C-0750Y	NAS1130-6FL20P	MS21209F6-20P



Tangless code	MA/NAS	MS (Equivalent)	Tangless code	MA/NAS	MS (Equivalent)*	Tangless code	MA/NAS	MS (Equivalent)*
Metric								
2TLM-2X.4C-2	N/A	MA3329-140	2TLM-2X.4C-2W	N/A	MA3330-140	2TLM-2X.4C-2Y	N/A	MA3331-140
2TLM-2X.4C-3	N/A	MA3329-190	2TLM-2X.4C-3W	N/A	MA3330-190	2TLM-2X.4C-3Y	N/A	MA3331-190
2TLM-2X.4C-4	N/A	MA3329-240	2TLM-2X.4C-4W	N/A	MA3330-240	2TLM-2X.4C-4Y	N/A	MA3331-240
2TLM-2.5X.45C-2.5	NA0276M2AL10	MA3329-101	2TLM-2.5X.45C-2.5W	NA0276M2AL10D	MA3330-101	2TLM-2.5X.45C-2.5Y	NA0276M2AL10P	MA3331-101
2TLM-2.5X.45C-3.8	NA0276M2AL15	MA3329-151	2TLM-2.5X.45C-3.8W	NA0276M2AL15D	MA3330-151	2TLM-2.5X.45C-3.8Y	NA0276M2AL15P	MA3331-151
2TLM-2.5X.45C-5	NA0276M2AL20	MA3329-201	2TLM-2.5X.45C-5W	NA0276M2AL20D	MA3330-201	2TLM-2.5X.45C-5Y	NA0276M2AL20P	MA3331-201
2TLM-2.5X.45C-6.3	NA0276M2AL25	MA3329-251	2TLM-2.5X.45C-6.3W	NA0276M2AL25D	MA3330-251	2TLM-2.5X.45C-6.3Y	NA0276M2AL25P	MA3331-251
2TLM-2.5X.45C-7.5	NA0276M2AL30	MA3329-301	2TLM-2.5X.45C-7.5W	NA0276M2AL30D	MA3330-301	2TLM-2.5X.45C-7.5Y	NA0276M2AL30P	MA3331-301
2TLM-3X.5C-3	NA0276M3L10	MA3329-102	2TLM-3X.5C-3W	NA0276M3L10D	MA3330-102	2TLM-3X.5C-3Y	NA0276M3L10P	MA3331-102
2TLM-3X.5C-4.5	NA0276M3L15	MA3329-152	2TLM-3X.5C-4.5W	NA0276M3L15D	MA3330-152	2TLM-3X.5C-4.5Y	NA0276M3L15P	MA3331-152
2TLM-3X.5C-6	NA0276M3L20	MA3329-202	2TLM-3X.5C-6W	NA0276M3L20D	MA3330-202	2TLM-3X.5C-6Y	NA0276M3L20P	MA3331-202
2TLM-3X.5C-7.5	NA0276M3L25	MA3329-252	2TLM-3X.5C-7.5W	NA0276M3L25D	MA3330-252	2TLM-3X.5C-7.5Y	NA0276M3L25P	MA3331-252
2TLM-3X.5C-9.0	NA0276M3L30	MA3329-302	2TLM-3X.5C-9.0W	NA0276M3L30D	MA3330-302	2TLM-3X.5C-9.0Y	NA0276M3L30P	MA3331-302
2TLM-4X.7C-4	NA0276M4L10	MA3339-104	2TLM-4X.7C-4W	NA0276M4L10D	MA3339-104	2TLM-4X.7C-4Y	NA0276M4L10P	MA3339-104
2TLM-4X.7C-6	NA0276M4L15	MA3329-154	2TLM-4X.7C-6W	NA0276M4L15D	MA3330-154	2TLM-4X.7C-6Y	NA0276M4L15P	MA3331-154
2TLM-4X.7C-8	NA0276M4L20	MA3329-204	2TLM-4X.7C-8W	NA0276M4L20D	MA3330-204	2TLM-4X.7C-8Y	NA0276M4L20P	MA3331-204
2TLM-4X.7C-10	NA0276M4L25	MA3329-254	2TLM-4X.7C-10W	NA0276M4L25D	MA3330-254	2TLM-4X.7C-10Y	NA0276M4L25P	MA3331-254
2TLM-4X.7C-12	NA0276M4L30	MA3329-304	2TLM-4X.7C-12W	NA0276M4L30D	MA3330-304	2TLM-4X.7C-12Y	NA0276M4L30P	MA3331-304
2TLM-5X.8C-5	NA0276M5L10	MA3329-105	2TLM-5X.8C-5W	NA0276M5L10D	MA3330-105	2TLM-5X.8C-5Y	NA0276M5L10P	MA3331-105
2TLM-5X.8C-7.5	NA0276M5L15	MA3329-155	2TLM-5X.8C-7.5W	NA0276M5L15D	MA3330-155	2TLM-5X.8C-7.5Y	NA0276M5L15P	MA3331-155
2TLM-5X.8C-10	NA0276M5L20	MA3329-205	2TLM-5X.8C-10W	NA0276M5L20D	MA3330-205	2TLM-5X.8C-10Y	NA0276M5L20P	MA3331-205
2TLM-5X.8C-12.5	NA0276M5L25	MA3329-255	2TLM-5X.8C-12.5W	NA0276M5L25D	MA3330-255	2TLM-5X.8C-12.5Y	NA0276M5L25P	MA3331-255
2TLM-5X.8C-15	NA0276M5L30	MA3329-305	2TLM-5X.8C-15W	NA0276M5L30D	MA3330-305	2TLM-5X.8C-15Y	NA0276M5L30P	MA3331-305
2TLM-6X1C-6	NA0276M6L10	MA3329-106	2TLM-6X1C-6W	NA0276M6L10D	MA3330-106	2TLM-6X1C-6Y	NA0276M6L10P	MA3331-106
2TLM-6X1C-9	NA0276M6L15	MA3329-156	2TLM-6X1C-9W	NA0276M6L15D	MA3330-156	2TLM-6X1C-9Y	NA0276M6L15P	MA3331-156
2TLM-6X1C-12	NA0276M6L20	MA3329-206	2TLM-6X1C-12W	NA0276M6L20D	MA3330-206	2TLM-6X1C-12Y	NA0276M6L20P	MA3331-206
2TLM-6X1C-15	NA0276M6L25	MA3329-256	2TLM-6X1C-15W	NA0276M6L25D	MA3330-256	2TLM-6X1C-15Y	NA0276M6L25P	MA3331-256
2TLM-6X1C-18	NA0276M6L30	MA3329-306	2TLM-6X1C-18W	NA0276M6L30D	MA3330-306	2TLM-6X1C-18Y	NA0276M6L30P	MA3331-306
2TLM-8X1.25C-8	NA0276M8L10	MA3329-109	2TLM-8X1.25C-8W	NA0276M8L10D	MA3330-109	2TLM-8X1.25C-8Y	NA0276M8L10P	MA3331-109
2TLM-8X1.25C-12	NA0276M8L15	MA3329-159	2TLM-8X1.25C-12W	NA0276M8L15D	MA3330-159	2TLM-8X1.25C-12Y	NA0276M8L15P	MA3331-159
2TLM-8X1.25C-16	NA0276M8L20	MA3329-209	2TLM-8X1.25C-16W	NA0276M8L20D	MA3330-209	2TLM-8X1.25C-16Y	NA0276M8L20P	MA3331-209
2TLM-8X1.25C-20	NA0276M8L25	MA3329-259	2TLM-8X1.25C-20W	NA0276M8L25D	MA3330-259	2TLM-8X1.25C-20Y	NA0276M8L25P	MA3331-259
2TLM-8X1.25C-24	NA0276M8L30	MA3329-260	2TLM-8X1.25C-24W	NA0276M8L30D	MA3330-260	2TLM-8X1.25C-24Y	NA0276M8L30P	MA3331-260
2TLM-10X1.5C-10	NA0276M10L10	MA3329-111	2TLM-10X1.5C-10W	NA0276M10L10D	MA3330-111	2TLM-10X1.5C-10Y	NA0276M10L10P	MA3331-111
2TLM-10X1.5C-15	NA0276M10L15	MA3329-161	2TLM-10X1.5C-15W	NA0276M10L15D	MA3330-161	2TLM-10X1.5C-15Y	NA0276M10L15P	MA3331-161
2TLM-10X1.5C-20	NA0276M10L20	MA3329-211	2TLM-10X1.5C-20W	NA0276M10L20D	MA3330-211	2TLM-10X1.5C-20Y	NA0276M10L20P	MA3331-211
2TLM-10X1.5C-25	NA0276M10L25	MA3329-261	2TLM-10X1.5C-25W	NA0276M10L25D	MA3330-261	2TLM-10X1.5C-25Y	NA0276M10L25P	MA3331-261
2TLM-12X1.75C-12	NA0276M12L10	MA3329-114	2TLM-12X1.75C-12W	NA0276M12L10D	MA3330-114	2TLM-12X1.75C-12Y	NA0276M12L10P	MA3331-114
2TLM-12X1.75C-18	NA0276M12L15	MA3329-164	2TLM-12X1.75C-18W	NA0276M12L15D	MA3330-164	2TLM-12X1.75C-18Y	NA0276M12L15P	MA3331-164
2TLM-12X1.75C-24	NA0276M12L20	MA3329-214	2TLM-12X1.75C-24W	NA0276M12L20D	MA3330-214	2TLM-12X1.75C-24Y	NA0276M12L20P	MA3331-214



KATO CoilThread® Tanged Inserts

Tanged threaded insert

Compliant with AS7275, NASM8846-33537-122076-124651-21209, AS5272, ASME B18.29.1, MA3279-3329-1565-1567, RoHs, DFARS,



ADVATEX

CHARACTERISTICS

The inserts are available as a standard in AISI304 stainless steel (AS7245, 18-10 stainless steel), cold-rolled to achieve a tensile strength of 1400 N/mm² (200,000 psi) and a surface hardness of 43-50 HRc. Cold rolling enables the production of a superior-quality thread with a very high surface finish, extending the life of the assembly by reducing thread wear due to friction and the effects of galvanic corrosion.

Standard AISI304 rolled threads are suitable for use in temperatures ranging from -195.6°C to +426.7°C (-320°F to +800°F). They are also available with Dry-Lube, Cadmium, or Silver treatments. Once installed, they form a threaded class of 4H-5H or 2B-3B, accommodating M, MJ, UN, and UNJ screws. They come in Metric, UNC, UNF sizes, available in Free Running or Self-Locking versions, and in Coil form for automated applications.

COMPLIANCES

KATO - Advanex tapered threads are compliant with aerospace and military standards NASM8846-33537-122076-124651-21209, AS5272, ASME B18.29.1, MA3379-3329-1565-1567, etc., and adhere to RoHs and DFARS directives.



TYPICAL APPLICATIONS

AEROSPACE: Fuel injection systems, Fuel pumps, Alternators, Missiles, Rotating actuators, Housings, Galleys, Braking systems, Aircraft seats, etc.

ELECTRONIC: Computers for harsh environments, Portable radios, Military racks for control electronics, Various containers, Mobile phone transmitters, Heat sinks, Electric motors and generators, etc.

AUTOMOTIVE: Transmission cases, Engines, Dashboards, Locomotive cabs, Steering components, Oil filters, etc.

OTHER: Cameras, Vending machines, Equipment and tools for the medical sector, Automatic machines, etc.

KATO - Advanex is utilized in the production programs of major companies leading in the manufacturing of aircraft, electronic devices, and mechanical components for the aerospace, military, automotive, missile, F1 cars, heavy-duty vehicles, etc.





SIZES



Thread	Size code			Length					Ø at free state		N. of coils at free state					Hole diameter	
	FR	SL	Fil.	1d	1.5d	2d	2.5d*	3d*	Min	Max	1d	1.5d	2d	2.5d	3d	Aluminum	Acciaio
METRIC																	
M2.5	TNM	TLM	2.5x0.45	2.5	3.8	5	6.3	7.5	3.20	3.70	3.375	5.750	8.125	10.500	12.750	2.55	2.65
M3	TNM	TLM	3x0.5	3	4.5	6	7.5	9	3.80	4.35	3.750	6.375	8.875	11.375	13.875	3.15	3.20
M4	TNM	TLM	4x0.7	4	6	8	10	12	5.05	5.60	3.625	6.125	8.625	11.125	13.625	4.20	4.25
M5	TNM	TLM	5x0.8	5	7.5	10	12.5	15	6.25	6.80	4.125	6.875	9.625	12.375	15.125	5.20	5.30
M6	TNM	TLM	6x1	6	9	12	18	24	7.40	7.95	4.000	6.750	9.500	12.125	14.875	6.25	6.30
M8	TNM	TLM	8x1.25	8	12	16	20	24	9.80	10.35	4.500	7.875	10.250	13.250	16.125	8.30	8.40
M10	TNM	TLM	10x1.5	10	15	20	25	30	11.95	12.50	4.875	8.000	11.125	14.250	17.375	10.50	10.50
M12	TNM	TLM	12x1.75	12	16	24	30	36	14.30	15.00	5.000	8.125	11.500	14.675	17.875	12.50	12.50
UNC																	
2-56	TNC	TLC	02C	.086	.129	.172	.215	.258	.110	.119	3.000	5.250	7.375	9.625	11.875	3/32 (.0938)	#41 (.0960)
3-48	TNC	TLC	03C	.099	.148	.198	.248	.297	.128	.139	2.875	5.000	7.250	9.375	11.500	#36 (.1065)	7/64 (.1094)
4-40	TNC	TLC	04C	.112	.168	.224	.280	.336	.144	.159	2.750	4.750	6.750	8.875	10.875	#31 (.1200)	#31 (.1200)
5-40	TNC	TLC	05C	.125	.188	.250	.312	.375	.158	.173	3.250	5.500	7.750	10.000	12.250	3.4mm (.1339)	#29 (.1360)
6-32	TNC	TLC	06C	.138	.207	.276	.345	.414	.178	.193	2.750	4.750	6.875	8.875	10.875	#26 (.1470)	#25 (.1495)
8-32	TNC	TLC	2C	.164	.246	.328	.410	.492	.205	.220	3.500	6.000	8.375	10.750	13.250	#17 (.1730)	#16 (.1770)
10-24	TNC	TLC	3C	.190	.285	.380	.475	.570	.244	.259	2.875	5.000	7.125	9.250	11.375	13/64 (.2031)	#5 (.2055)
12-24	TNC	TLC	1C	.216	.324	.432	.540	.648	.270	.285	3.500	6.000	8.375	10.625	13.128	#1 (.2280)	#1 (.2280)
1/4-20	TNC	TLC	4C	.250	.375	.500	.625	.750	.310	.330	3.375	5.750	8.000	10.375	12.750	H (.2660)	H (.2660)
5/16-18	TNC	TLC	5C	.312	.469	.625	.781	.938	.380	.400	4.000	6.625	9.250	11.875	14.625	Q (.3320)	Q (.3320)
3/8-16	TNC	TLC	6C	.375	.562	.750	.938	1.125	.452	.472	4.375	7.250	10.000	12.875	15.750	X (.3970)	X (.3970)
7/16-14	TNC	TLC	7C	.438	.656	.875	1.094	1.312	.526	.551	4.500	7.375	10.250	13.125	16.125	29/64 (.4531)	29/64 (.4531)
1/2-13	TNC	TLC	8C	.500	.750	1.000	1.250	1.500	.597	.622	4.875	7.875	11.000	14.125	17.125	33/64 (.5156)	17/32 (.5312)
UNF																	
3-56	TNF	TLF	03C	.099	.148	.198	.248	.297	.131	.146	3.375	5.625	8.000	10.375	12.625	#37 (.1040)	#36 (.1065)
4-48	TNF	TLF	04C	.112	.168	.224	.280	.336	.147	.162	3.375	5.625	7.875	10.250	12.500	3mm (.1181)	#31 (.1200)
6-40	TNF	TLF	06C	.138	.207	.276	.345	.414	.173	.193	3.500	6.000	8.375	10.750	13.250	#26 (.1470)	#25 (.1495)
8-36	TNF	TLF	2C	.164	.246	.328	.410	.492	.204	.224	3.875	6.500	9.125	11.625	14.250	#17 (.1730)	#16 (.1770)
10-32	TNF	TLF	3C	.190	.285	.380	.475	.570	.236	.256	4.125	6.875	9.500	12.250	14.875	#7 (.2010)	13/64 (.2031)
1/4-28	TNF	TLF	4C	.250	.375	.500	.625	.750	.306	.326	5.000	8.250	11.375	14.500	17.625	G (.2610)	6.7mm (.2638)
5/16-24	TNF	TLF	5C	.312	.469	.625	.781	.938	.380	.400	5.500	8.875	12.250	15.625	19.000	21/64 (.3281)	21/64 (.3281)
3/8-24	TNF	TLF	6C	.375	.562	.750	.938	1.125	.448	.468	6.875	11.000	15.000	19.125	23.125	25/64 (.3906)	25/64 (.3906)
7/16-20	TNF	TLF	7C	.438	.656	.875	1.094	1.312	.524	.549	6.625	10.625	14.625	18.500	22.500	29/64 (.4531)	29/64 (.4531)
1/2-20	TNF	TLF	8C	.500	.750	1.000	1.250	1.500	.592	.617	7.875	12.375	16.875	21.375	25.875	33/64 (.5156)	33/64 (.5156)

*Available upon request

METRIC CODING

T N M 2.5 X0.45 C -6.3 SF

Type: T = Tanged

Style: N = Free Running
L = Locking

Thread: M = Metric

Pitch: ie. X0.45 = 4.5mm

Material: C = AISI304

Size (internal thread): ie. 2.5 = M2.5

Packaging/Treatment: = loose non-treated
SF = strip feed non-treated

Length once installed: ie. 6.3 = 6.3mm - 2.5D

UN CODING

T N C -06 C -0345 SF

Type: T = Tanged

Style: N = Free Running
L = Locking

Thread: C = Coarse thread
F = Fine thread

Material: C = AISI304

Size (internal thread): ie. -06C = 6-32

Packaging/Treatment: = loose non-treated
SF = strip feed non-treated

Length once installed: ie. -0345 = .345" - 2.5D

KFS-20 and KFS-25 ELECTRIC INSTALLATION TOOLS

Ideal for applications with medium to high installation volumes, the tool is lightweight, easy to use, and quiet. It has a clutch to prevent damage to the rods and automatic reverse for disengagement. It allows for quick change of the installation tool to quickly switch to installing a different size. It is used with 1/4HEX rod installation or removal tools.

KFS-20 usage range: M2 – M6 and 2-56 – 1/4.

KFS-25 usage range: M4 - M12 and 6-32 - 1/2”.



KFS-20 ELECTRIC TOOL

Code	Torque	Speed	Length A	Diameter B	Diameter C	Handle diameter	Weight	Attachment	Volt
KFS-20 (CT5420)	0.1-0.7 Nm 0.62-0.88 lbf-in	LOW 480 g/min	216mm 8.5"	11mm 0.428"	28mm 1.1"	33mm 1.28"	363 gr 12.8 oz	1/4 HEX	20-30 VDC
KFS-25(CT5425)	0.5-2.0 Nm 4.4-17.7 lbf-in	LOW 490 g/min HIGH 730 g/min	230mm 9.05"	13mm 0.51"	15mm 0.60"	38mm 1.49"	408 gr 14.4 oz	1/4 HEX	20-30 VDC

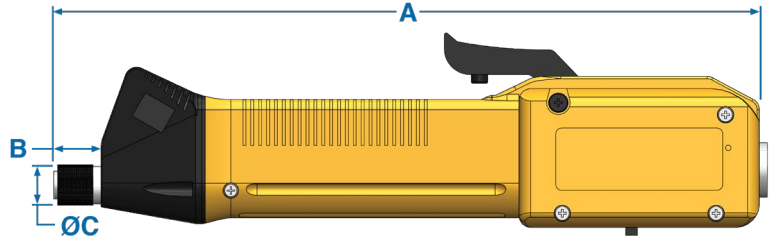
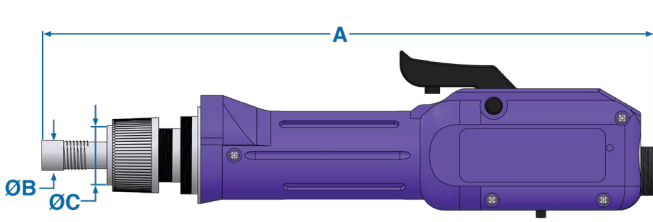

KFS20 NOSEPIECE

Thread	Adapter	Complete nosepiece	Replacement shaft
M2.5	CT5408-PA	KPEM-2.5	KPEM-2.5M
M3		KPEM-3	KPEM-3M
M4		KPEM-4	KPEM-4M
M5		KPEM-5	KPEM-5M
M6		KPEM-6	KPEM-6M
2-56		KPEC-02	KPEC-02M
4-40		KPEC-04	KPEC-04M
6-32		KPEC-06	KPEC-06M
8-32		KPEC-2	KPEC-2M
10-24		KPEC-3	KPEC-3M
1/4-20		KPEC-4	KPEC-4M
10-32		KPEF-3	KPEF-3M
1/4-28		KPEF-4	KPEF-4M



MANUAL INSTALLATION TOOL WITH PREWINDER

M2.5 KPHM-2.5 CIM-2.5	M3 KPHM-3 CIM-3	M4 KPHM-4 CIM-4	M5 KPHM-5 CIM-5	M6 KPHM-6 CIM-6	M8 KPHM-8 CIM-8	M10 KPHM-10 CIM-10	M12 KPHM-12 CIM-12	-	-
-	M3.5 KPHM-3.5	-	-	M7 KPHM-7	M8X1 KPHM-8X1	M10X1.25 KPHM-10X1.25	M12X1.25 KPHM-12X1.25	M12X1.5 KPHM-12X1.5	-
2-56 KPHC-02 CIC-02	4-40 KPHC-04 CIC-04	6-32 KPHC-06 CIC-06	8-32 KPHC-2 CIC-2	10-24 KPHC-3 CIC-3	1/4-20 KPHC-4 CIC-4	5/16-18 KPHC-5 CIC-5	3/8-16 KPHC-6 CIC-6	7/16-14 KPHC-7	1/2-13 KPHC-8
-	-	-	-	10-32 KPHF-3 CIF-3	1/4-28 KPHF-4 CIF-4	5/16-24 KPHF-5 CIF-5	3/8-24 KPHF-6 CIF-6	7/16-20 KPHF-7	1/2-20 KPHF-8



ROD INSTALLATION TOOL

M2.5 KHEM-2.5	M3 KHEM-3	M4 KHEM-4	M5 KHEM-5	M6 KHEM-6	M8 KHEM-8	-
2-56 KHEC-02	4-40 KHEC-04	6-32 KHEC-06	8-32 KHEC-2	10-24 KHEC-3	1/4-20 KHEC-4	10-32 KHEF-3



REMOVAL TOOL

Tipo	Metrico	UNC-UNF
KRTV-02	M2	2-56
KRTV-06	M2.2 M2.5 M3 M3.5 M4 M8x1 M10x1 M10x1.25 M12x1.25	3-48 3-56 4-40 4-48 5-40 6-32 6-40 8-32 8-36
KRTV-6	M5 M6 M7 M8 M10 M12x1.5	1/4-20 1/4-28 5/16-18 5/16-24 3/8-16 3/8-24
KRTV-16	M12 M14 M14x1.5	7/16-14 7/16-20 1/2-13 1/2-20



AUTOMATIC BREAK-OFF TOOL

Tipo	Metric	UNC-UNF
KTBT-02	M2 M2.2	2-56
KTBT-03	M2.5	3-48 3-56
KTBT-04	M3	4-40 4-48 5-40
KTBT-06	M3.5	6-32 6-40
KTBT-2	M4	8-32 8-36
KTBT-3	M5	10-24 10-32 12-14
KTBT-4	M6-7	1/4-20 1/4-28
KTBT-5	M8 M8x1	5/16-18 5/16-24
KTBT-6	M10 M10x1.25 M10x1	3/8-16 3/8-24
KTBT-7	-	7/16-14 7/16-20
KTBT-8	M12 M12x1.5 M12x1.25	1/2-13 1/2-20



PNEUMATIC INSTALLATION TOOL

Thread	Motor	Adapter	Clutch	Complete nosepiece	Replacement shaft	Thread	Complete Nosepiece	Replacement shaft		
	METRIC						METRIC			
M2.5	CT25017	CT9605	CT9602	KPAM-2.5	KPAM-2.5M	-	-	-		
M3				KPAM-3	KPAM-3M	M3.5	KPAM-4	KPAM-4M		
M4				KPAM-4	KPAM-4M	-	-	-		
M5				KPAM-5	KPAM-5M	-	-	-		
M6				KPAM-6	KPAM-6M	M7	KPAM-7	KPAM-7M		
M8				KPAM-8	KPAM-8M	M8X1	KPAM-8X1	KPAM-8MX1		
M10				CT9705	/	KPAM-10	KPAM-10M	M10X1.25	KPAM-10X1.25	KPAM-10MX1.25
M12						KPAM-12	KPAM-12M	M12X1.25	KPAM-12X1.25	KPAM-12MX1.25
-	-	-	M12X1.5			KPAM-12X1.5	KPAM-12MX1.5			
UNC						UNF				
2-56	CT25017	CT9605	CT9602	KPAC-02	KPAC-02M	-	-	-		
4-40				KPAC-04	KPAC-04M	-	-	-		
6-32				KPAC-06	KPAC-06M	-	-	-		
8-32				KPAC-2	KPAC-2M	-	-	-		
10-24				KPAC-3	KPAC-3M	10-32	KPAF-3	KPAF-3M		
1/4-20				KPAC-4	KPAC-4M	1/4-28	KPAF-4	KPAF-4M		
5/16-18				KPAC-5	KPAC-5M	5/16-24	KPAF-5	KPAF-5M		
3/8-16				KPAC-6	KPAC-6M	3/8-24	KPAF-6	KPAF-6M		
7/16-14	CT9705	/	KPAC-7	KPAC-7M	7/16-20	KPAF-7	KPAF-7M			
1/2-13			KPAC-8	KPAC-8M	1/2-20	KPAF-8	KPAF-8M			



METRIC											
Tanged Coil Thread	MS / MA Number	Tanged Coil Thread	MS / MA Number*	Tanged Coil Thread	MS / MA Number*	Tanged Coil Thread	MA/NAS	Tanged Coil Thread	MA/NAS	Tanged Coil Thread	MA/NAS
TNM-2X.4C-3	MA3279-190	TNM-2X.4C-3W	MA3280-190	TNM-2X.4C-3Y	MA3281-190	TLM-2X.4C-3	MA3329-190	TLM-2X.4C-3W	MA3330-190	TLM-2X.4C-3Y	MA3331-190
TNM-2X.4C-4	MA3279-240	TNM-2X.4C-4W	MA3280-240	TNM-2X.4C-4Y	MA3281-240	TLM-2X.4C-4	MA3329-240	TLM-2X.4C-4W	MA3330-240	TLM-2X.4C-4Y	MA3331-240
TNM-2X.4C-5	MA3279-290	TNM-2X.4C-5W	MA3280-290	TNM-2X.4C-5Y	MA3281-290	TLM-2X.4C-5	MA3329-290	TLM-2X.4C-5W	MA3330-290	TLM-2X.4C-5Y	MA3331-290
TNM-2X.4C-6	MA3279-340	TNM-2X.4C-6W	MA3280-340	TNM-2X.4C-6Y	MA3281-340	TLM-2X.4C-6	MA3329-340	TLM-2X.4C-6W	MA3330-340	TLM-2X.4C-6Y	MA3331-340
TNM-2.5X.45C-3.8	MA3279-151	TNM-2.5X.45C-3.8W	MA3280-151	TNM-2.5X.45C-3.8Y	MA3281-151	TLM-2.5X.45C-3.8	MA3329-151	TLM-2.5X.45C-3.8W	MA3330-151	TLM-2.5X.45C-3.8Y	MA3331-151
TNM-2.5X.45C-5	MA3279-201	TNM-2.5X.45C-5W	MA3280-201	TNM-2.5X.45C-5Y	MA3281-201	TLM-2.5X.45C-5	MA3329-201	TLM-2.5X.45C-5W	MA3330-201	TLM-2.5X.45C-5Y	MA3331-201
TNM-2.5X.45C-6.3	MA3279-251	TNM-2.5X.45C-6.3W	MA3280-251	TNM-2.5X.45C-6.3Y	MA3281-251	TLM-2.5X.45C-6.3	MA3329-251	TLM-2.5X.45C-6.3W	MA3330-251	TLM-2.5X.45C-6.3Y	MA3331-251
TNM-2.5X.45C-7.5	MA3279-301	TNM-2.5X.45C-7.5W	MA3280-301	TNM-2.5X.45C-7.5Y	MA3281-301	TLM-2.5X.45C-7.5	MA3329-301	TLM-2.5X.45C-7.5W	MA3330-301	TLM-2.5X.45C-7.5Y	MA3331-301
TNM-3X.5C-3	MA3279-102	TNM-3X.5C-3W	MA3280-102	TNM-3X.5C-3Y	MA3281-102	TLM-3X.5C-3	MA3329-102	TLM-3X.5C-3W	MA3330-102	TLM-3X.5C-3Y	MA3331-102
TNM-3X.5C-4.5	MA3279-152	TNM-3X.5C-4.5W	MA3280-152	TNM-3X.5C-4.5Y	MA3281-152	TLM-3X.5C-4.5	MA3329-152	TLM-3X.5C-4.5W	MA3330-152	TLM-3X.5C-4.5Y	MA3331-152
TNM-3X.5C-6	MA3279-202	TNM-3X.5C-6W	MA3280-202	TNM-3X.5C-6Y	MA3281-202	TLM-3X.5C-6	MA3329-202	TLM-3X.5C-6W	MA3330-202	TLM-3X.5C-6Y	MA3331-202
TNM-3X.5C-7.5	MA3279-252	TNM-3X.5C-7.5W	MA3280-252	TNM-3X.5C-7.5Y	MA3281-252	TLM-3X.5C-7.5	MA3329-252	TLM-3X.5C-7.5W	MA3330-252	TLM-3X.5C-7.5Y	MA3331-252
TNM-3X.5C-9	MA3279-302	TNM-3X.5C-9W	MA3280-302	TNM-3X.5C-9Y	MA3281-302	TLM-3X.5C-9	MA3329-302	TLM-3X.5C-9W	MA3330-302	TLM-3X.5C-9Y	MA3331-302
TNM-4X.7C-4	MA3279-104	TNM-4X.7C-4W	MA3280-104	TNM-4X.7C-4Y	MA3281-104	TLM-4X.7C-4	MA3329-104	TLM-4X.7C-4W	MA3330-104	TLM-4X.7C-4Y	MA3331-104
TNM-4X.7C-6	MA3279-154	TNM-4X.7C-6W	MA3280-154	TNM-4X.7C-6Y	MA3281-154	TLM-4X.7C-6	MA3329-154	TLM-4X.7C-6W	MA3330-154	TLM-4X.7C-6Y	MA3331-154
TNM-4X.7C-8	MA3279-204	TNM-4X.7C-8W	MA3280-204	TNM-4X.7C-8Y	MA3281-204	TLM-4X.7C-8	MA3329-204	TLM-4X.7C-8W	MA3330-204	TLM-4X.7C-8Y	MA3331-204
TNM-4X.7C-10	MA3279-254	TNM-4X.7C-10W	MA3280-254	TNM-4X.7C-10Y	MA3281-254	TLM-4X.7C-10	MA3329-254	TLM-4X.7C-10W	MA3330-254	TLM-4X.7C-10Y	MA3331-254
TNM-4X.7C-12	MA3279-304	TNM-4X.7C-12W	MA3280-304	TNM-4X.7C-12Y	MA3281-304	TLM-4X.7C-12	MA3329-304	TLM-4X.7C-12W	MA3330-304	TLM-4X.7C-12Y	MA3331-304
TNM-5X.8C-5	MA3279-105	TNM-5X.8C-5W	MA3280-105	TNM-5X.8C-5Y	MA3281-105	TLM-5X.8C-5	MA3329-105	TLM-5X.8C-5W	MA3330-105	TLM-5X.8C-5Y	MA3331-105
TNM-5X.8C-7.5	MA3279-155	TNM-5X.8C-7.5W	MA3280-155	TNM-5X.8C-7.5Y	MA3281-155	TLM-5X.8C-7.5	MA3329-155	TLM-5X.8C-7.5W	MA3330-155	TLM-5X.8C-7.5Y	MA3331-155
TNM-5X.8C-10	MA3279-205	TNM-5X.8C-10W	MA3280-205	TNM-5X.8C-10Y	MA3281-205	TLM-5X.8C-10	MA3329-205	TLM-5X.8C-10W	MA3330-205	TLM-5X.8C-10Y	MA3331-205
TNM-5X.8C-12.5	MA3279-255	TNM-5X.8C-12.5W	MA3280-255	TNM-5X.8C-12.5Y	MA3281-255	TLM-5X.8C-12.5	MA3329-255	TLM-5X.8C-12.5W	MA3330-255	TLM-5X.8C-12.5Y	MA3331-255
TNM-5X.8C-15	MA3279-305	TNM-5X.8C-15W	MA3280-305	TNM-5X.8C-15Y	MA3281-305	TLM-5X.8C-15	MA3329-305	TLM-5X.8C-15W	MA3330-305	TLM-5X.8C-15Y	MA3331-305
TNM-6X1C-6	MA3279-106	TNM-6X1C-6W	MA3280-106	TNM-6X1C-6Y	MA3281-106	TLM-6X1C-6	MA3329-106	TLM-6X1C-6W	MA3330-106	TLM-6X1C-6Y	MA3331-106
TNM-6X1C-9	MA3279-156	TNM-6X1C-9W	MA3280-156	TNM-6X1C-9Y	MA3281-156	TLM-6X1C-9	MA3329-156	TLM-6X1C-9W	MA3330-156	TLM-6X1C-9Y	MA3331-156
TNM-6X1C-12	MA3279-206	TNM-6X1C-12W	MA3280-206	TNM-6X1C-12Y	MA3281-206	TLM-6X1C-12	MA3329-206	TLM-6X1C-12W	MA3330-206	TLM-6X1C-12Y	MA3331-206
TNM-6X1C-15	MA3279-256	TNM-6X1C-15W	MA3280-256	TNM-6X1C-15Y	MA3281-256	TLM-6X1C-15	MA3329-256	TLM-6X1C-15W	MA3330-256	TLM-6X1C-15Y	MA3331-256
TNM-6X1C-18	MA3279-306	TNM-6X1C-18W	MA3280-306	TNM-6X1C-18Y	MA3281-306	TLM-6X1C-18	MA3329-306	TLM-6X1C-18W	MA3330-306	TLM-6X1C-18Y	MA3331-306
TNM-8X1.25C-8	MA3279-109	TNM-8X1.25C-8W	MA3280-109	TNM-8X1.25C-8Y	MA3281-109	TLM-8X1.25C-8	MA3329-109	TLM-8X1.25C-8W	MA3330-109	TLM-8X1.25C-8Y	MA3331-109
TNM-8X1.25C-12	MA3279-159	TNM-8X1.25C-12W	MA3280-159	TNM-8X1.25C-12Y	MA3281-159	TLM-8X1.25C-12	MA3329-159	TLM-8X1.25C-12W	MA3330-159	TLM-8X1.25C-12Y	MA3331-159
TNM-8X1.25C-16	MA3279-209	TNM-8X1.25C-16W	MA3280-209	TNM-8X1.25C-16Y	MA3281-209	TLM-8X1.25C-16	MA3329-209	TLM-8X1.25C-16W	MA3330-209	TLM-8X1.25C-16Y	MA3331-209
TNM-8X1.25C-20	MA3279-259	TNM-8X1.25C-20W	MA3280-259	TNM-8X1.25C-20Y	MA3281-259	TLM-8X1.25C-20	MA3329-259	TLM-8X1.25C-20W	MA3330-259	TLM-8X1.25C-20Y	MA3331-259
TNM-8X1.25C-24	MA3279-260	TNM-8X1.25C-24W	MA3280-260	TNM-8X1.25C-24Y	MA3281-260	TLM-8X1.25C-24	MA3329-260	TLM-8X1.25C-24W	MA3330-260	TLM-8X1.25C-24Y	MA3331-260
TNM-10X1.5C-10	MA3279-111	TNM-10X1.5C-10W	MA3280-111	TNM-10X1.5C-10Y	MA3281-111	TLM-10X1.5C-10	MA3329-111	TLM-10X1.5C-10W	MA3330-111	TLM-10X1.5C-10Y	MA3331-111
TNM-10X1.5C-15	MA3279-161	TNM-10X1.5C-15W	MA3280-161	TNM-10X1.5C-15Y	MA3281-161	TLM-10X1.5C-15	MA3329-161	TLM-10X1.5C-15W	MA3330-161	TLM-10X1.5C-15Y	MA3331-161
TNM-10X1.5C-20	MA3279-211	TNM-10X1.5C-20W	MA3280-211	TNM-10X1.5C-20Y	MA3281-211	TLM-10X1.5C-20	MA3329-211	TLM-10X1.5C-20W	MA3330-211	TLM-10X1.5C-20Y	MA3331-211
TNM-10X1.5C-25	MA3279-261	TNM-10X1.5C-25W	MA3280-261	TNM-10X1.5C-25Y	MA3281-261	TLM-10X1.5C-25	MA3329-261	TLM-10X1.5C-25W	MA3330-261	TLM-10X1.5C-25Y	MA3331-261
TNM-10X1.5C-30	MA3279-311	TNM-10X1.5C-30W	MA3280-311	TNM-10X1.5C-30Y	MA3281-311	TLM-10X1.5C-30	MA3329-311	TLM-10X1.5C-30W	MA3330-311	TLM-10X1.5C-30Y	MA3331-311
TNM-12X1.75C-12	MA3279-114	TNM-12X1.75C-12W	MA3280-114	TNM-12X1.75C-12Y	MA3281-114	TLM-12X1.75C-12	MA3329-114	TLM-12X1.75C-12W	MA3330-114	TLM-12X1.75C-12Y	MA3331-114
TNM-12X1.75C-18	MA3279-164	TNM-12X1.75C-18W	MA3280-164	TNM-12X1.75C-18Y	MA3281-164	TLM-12X1.75C-18	MA3329-164	TLM-12X1.75C-18W	MA3330-164	TLM-12X1.75C-18Y	MA3331-164
TNM-12X1.75C-24	MA3279-214	TNM-12X1.75C-24W	MA3280-214	TNM-12X1.75C-24Y	MA3281-214	TLM-12X1.75C-24	MA3329-214	TLM-12X1.75C-24W	MA3330-214	TLM-12X1.75C-24Y	MA3331-214
TNM-12X1.75C-30	MA3279-264	TNM-12X1.75C-30W	MA3280-264	TNM-12X1.75C-30Y	MA3281-264	TLM-12X1.75C-30	MA3329-264	TLM-12X1.75C-30W	MA3330-264	TLM-12X1.75C-30Y	MA3331-264
TNM-12X1.75C-36	MA3279-314	TNM-12X1.75C-36W	MA3280-314	TNM-12X1.75C-36Y	MA3281-314	TLM-12X1.75C-36	MA3329-314	TLM-12X1.75C-36W	MA3330-314	TLM-12X1.75C-36Y	MA3331-314

REGULATIONS OF REFERENCE

Tanged and Tangless inserts		
AS9100B - DFARs - EAR - FAR - ITAR - REACH - RoHS		
MS/NAS	AS/NASM	Description
UNC - UNF		
AS7245	Invariata	Insert, Screw Thread, Helical Coil, Corrosion Resistant Steel
MIL-I-8846	NASM8846	Inserts, Screw Thread, Helical Coil - Procurement Spec
MIL-L-46010	AS5272	Dry Film Lubricant (Type I) - Optional coating
MIL-T-21309	A-A-59158	Tools for Inserting and Extracting Helical Coil Inserts
MS122076 serie	NASM122076 serie	Insert, Corrosion Resistant Helical Coarse Thread
MS124651 serie	NASM124651 serie	Insert, Corrosion Resistant Helical Fine Thread
MS21208*	NASM122076 NASM12651	Insert-Screw Thread Free Running
MS21209	NASM21209	Insert-Screw Thread Screw-Locking
MS33537	NASM33537	Assembly and Dimensions, Helical Coil Insert
-	NAS1130	Tangless Inserts, Free-Running and Locking United
-	QQ-P-416	Cadmium Plating (Type II) - Optional coating
METRIC		
-	NA0276	Tangless Inserts, Free-Running and Locking Metric
	MA3279	Inserts, Metric, Free-Running, Helical Coil Uncoated
	MA3280	Inserts, Metric, Free-Running, Helical Coil Lubricated
	MA3281	Inserts, Metric, Free-Running, Helical Coil Cadmium Plated
	MA3329	Inserts, Metric, Locking, Helical Coil Uncoated
	MA3330	Inserts, Metric, Locking, Helical Coil Lubricated
	MA3331	Inserts, Metric, Locking, Helical Coil Cadmium Plated
	MA1565	Procurement Standard, Metric Helical Coil Inserts
	MA1567	Assembly Dimensions, Metric Helical Coil Inserts

*Regulation MS21208 has been surpassed by MS122076 & MS124651, and subsequently surpassed by NASM122076 & NASM124651.

Special notes: In 1998-1999, the military standard 'Military Standard' (MS) for 'Unified Size' threaded inserts was surpassed by the 'National Aerospace Standard' (NAS) with an 'M' suffix indicating its previous affiliation with a military standard.

LOCKONE

REVOLUTIONARY LOCKING SYSTEM
NAS3351 COMPLIANT

Prevents loosening of standard nuts or bolts caused by strong vibrations. When LockOne is tightened against the nut, it prevents loosening. Installs with standard wrenches.

Easy to remove – Reusable - Corrosion-resistant

Replaces: cotter pins, brake cables, adhesive compounds, double nuts, lock nuts, crown nuts, serrated nuts or washers, and other types of locking fasteners.

Ideal for a wide range of applications in industrial, railway, transportation, construction, aerospace, energy, etc.



EFFECTIVE

The LockOne fastening elements have undergone accelerated vibration testing with 30,000 cycles in accordance with NAS3350 regulations (National Aerospace Specification for impact-type vibration testing). After 180,000 cycles, the assembly to which LockOne was applied remained securely fastened. LockOne can be easily applied to components already in use. It is reusable and does not degrade with each loosening cycle.

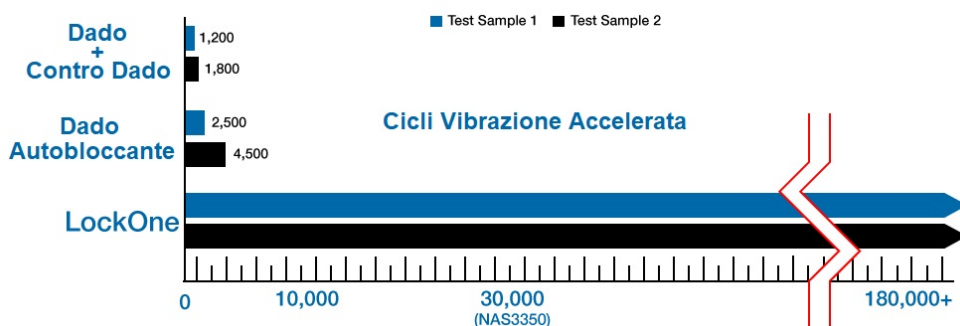
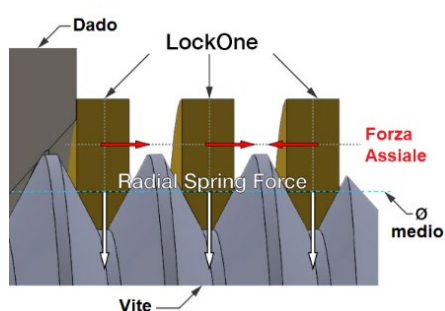

DESIGN AND INSTALLATION

Designing for the use of LockOne couldn't be easier; simply consider an extra length of three threads in the bolt. Its compact nature makes it ideal for projects with weight restrictions and maintenance programs. When using any fastening element with a degradable locking function, such as a compound or a nylon element embedded in the nut, replacement is necessary during maintenance interventions, as these systems are either single-use or have degraded locking features in subsequent uses after the first. With LockOne, the locking function does not degrade and can be removed and reused. LockOne is quick and easy to install—no compound to apply; a standard 12-point hex socket wrench is all that's needed to simultaneously install LockOne and the nut.



ENVIRONMENTALLY FRIENDLY

LockOne is designed for challenging environments without the use of hazardous chemical coatings. Made from AISI 304 WPB stainless steel, LockOne is naturally resistant to corrosion.





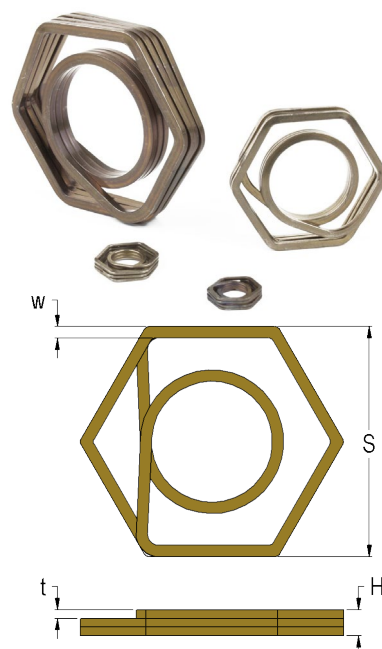



SIZES

Code	Thread	S mm	H mm	W mm	T mm	Weight gr
LO-M4	M4x0.7	7	1.4	0.50	0.35	0.24gr
LO-M5	M5x0.8	8	1.6	0.60	0.40	0.24gr
LO-M6	M6x1	10	2.0	0.70	0.50	0.45gr
LO-M8	M8x1.25	13	2.5	0.88	0.63	0.95gr
LO-M10	M10x1.5	17	3.0	1.05	0.75	1.79gr
LO-M12	M12x1.75	19	3.5	1.23	0.88	2.83gr
LO-M16	M16x2	24	4.0	1.40	1.00	4.78gr
LO-M20	M20x2.5	30	5.0	1.75	1.25	9.39gr
LO-M22	M22x2.5	32	5.0	1.75	1.25	10.12gr
LO-M24	M24x3	36	6.0	2.10	1.50	16.21gr
LO-C4	UNC ¼-20	0.48"	0.11"	0.03"	0.03"	0.80gr
LO-C5	UNC 5/16-18	0.50"	0.11"	0.03"	0.03"	0.80gr
LO-C6	UNC 3/8-16	0.55"	0.13"	0.04"	0.03"	1.30gr
LO-C7	UNC 7/16-14	0.71"	0.14"	0.05"	0.03"	2.31gr
LO-C8	UNC ½-13	0.75"	0.16"	0.05"	0.04"	3.00gr
LO-C10	UNC 5/8-11	0.93"	0.18"	0.06"	0.04"	4.48gr
LO-C12	UNC ¾-10	1.12"	0.22"	0.07"	0.05"	9.40gr
LO-C14	UNC 7/8-9	1.30"	0.22"	0.07"	0.05"	10.10gr
LO-C16	UNC 1-8	1.49"	0.28"	0.08"	0.06"	16.25gr



*M4 upon request **UNC sizes upon request

COMPARISON

Fastener	Ease of installation	Reusable	Single component	Strong vibrations resistant	Low cost	Non-destructive
 LockOne	✓	✓	✓	✓	✓	✓
 Crown nut	✗	✓	✗	✓	✗	✗
 Lock nut	✓	✗	✓	✗	✓	✓
 Pin-Lock	✓	✗	✗	✓	✗	✗
 Double nut	✓	✓	✗	✗	✓	✓
 Serrated nut	✓	✗	✓	✗	✓	✗
 Specials	✗	✗	✗	✓	✗	✓
 Adhesive compounds	✗	✗	✗	✗	✗	✓

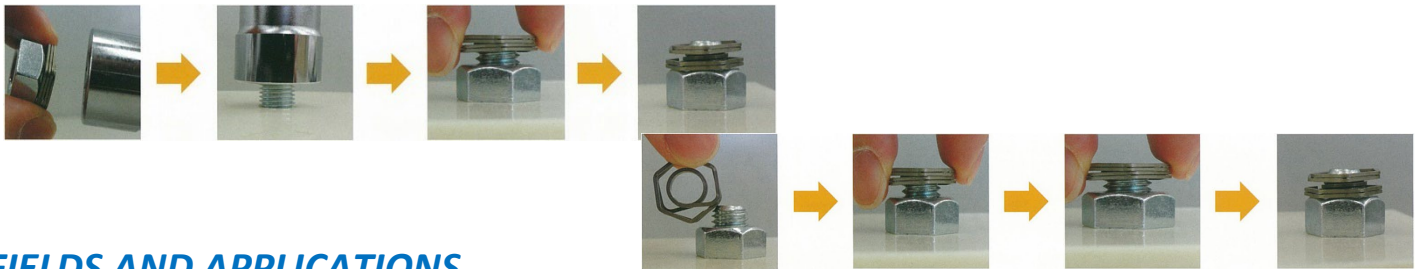

FIELDS AND APPLICATIONS

LockOne can be used in a wide range of applications and has proven high performance.

Railway Sector: sleeper attachments, rail joints (LockOne is under comparative study by the Japanese Railway Technical Research Institute).

Construction:

Energy: supports for solar panels.

Roads: bridge and tunnel joints, installation of fiber optic cables (LockOne is authorized and approved by the Japanese NEXCO – Nippon Expressway Research Institute).

LockOne is approved and used by many organizations, including the Tokyo Metro, Toyoda, and Japanese Railways.

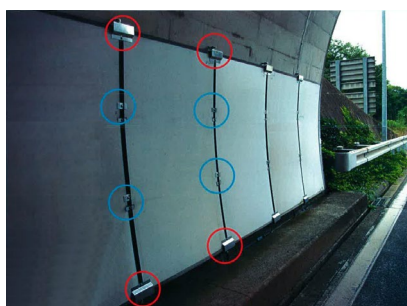
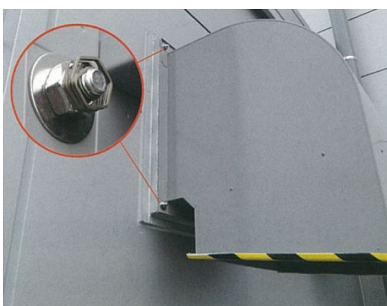
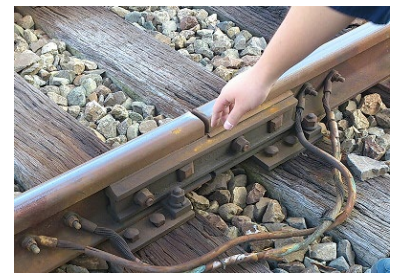

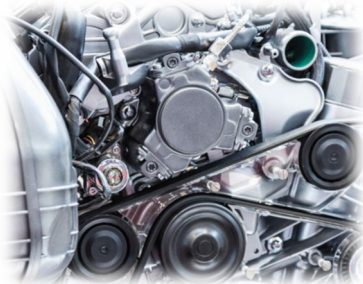

CONSTANT TORQUE HINGES WITH DAMPING

HexaTorq

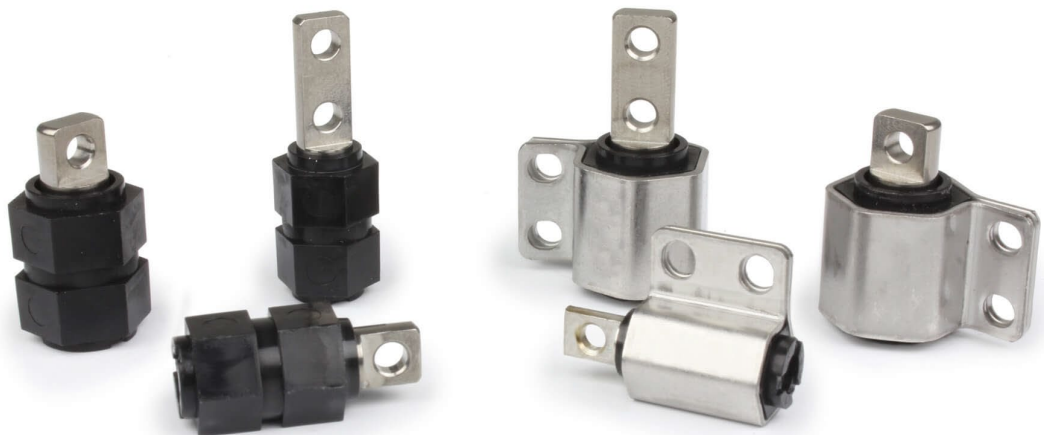

SureTorq



HexaTorq hinges

Conventional spring hinges, when used in high-temperature environments or applications where high usage cycles lead to increased hinge temperature, may lose their stiffness and become stuck, causing damage to mating parts.

KATO Hexatorq Hinges (KH) feature an innovative design utilizing modern plastic resin that does not require lubrication. In high-temperature applications, Hexatorq hinges exhibit a predictable torque decrease, returning to the original torque values after a brief cooling period. This ensures that no damage occurs to the parts due to locking.

Hexatorq hinges are available in standard sizes to meet the requirements of common applications. Design, durability, and product validation tests have been conducted. By using KATO Hexatorq hinges, it is possible to significantly reduce design and production lead times.

Features and Benefits

- Constant torque, designed for 30,000 cycles and beyond without failures.
- Smooth operation with a 360° working range.
- Maintains position throughout the working range without elastic rebound.
- Corrosion-resistant stainless steel with a special resin design.
- Lightweight, compact, maximizing space and weight savings.
- Hexagonal configuration allows easy mounting in mold housing without brackets.
- No lubrication required! Eliminates the possibility of contamination and corrosion of sensitive parts.
- FOD-free design (Foreign Object Debris Free), absence of metal-on-metal friction means no damage caused by the presence of metallic particles.

HexaTorq Application example

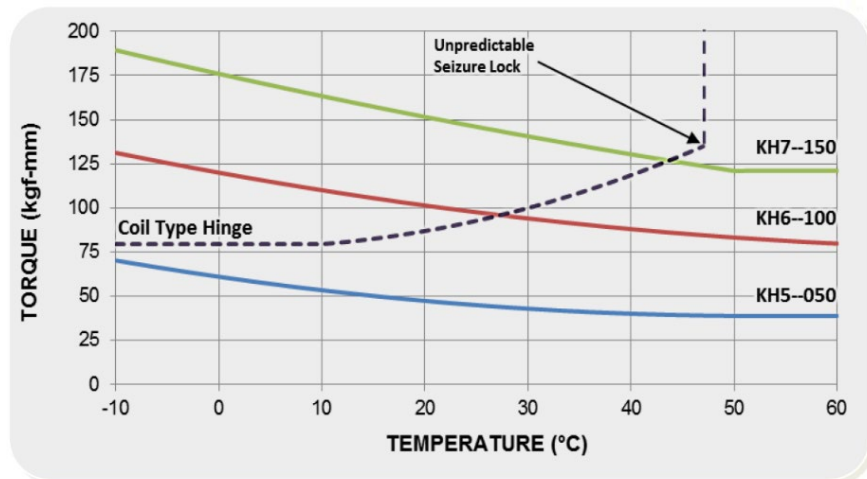
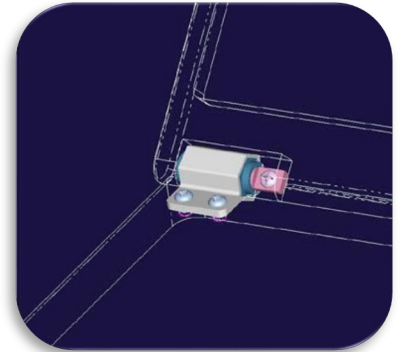

Temperature
Compared to conventional hinges, Hexatorq hinges exhibit a predictably lower torque in high-temperature applications, returning to the original torque values after a brief cooling period.

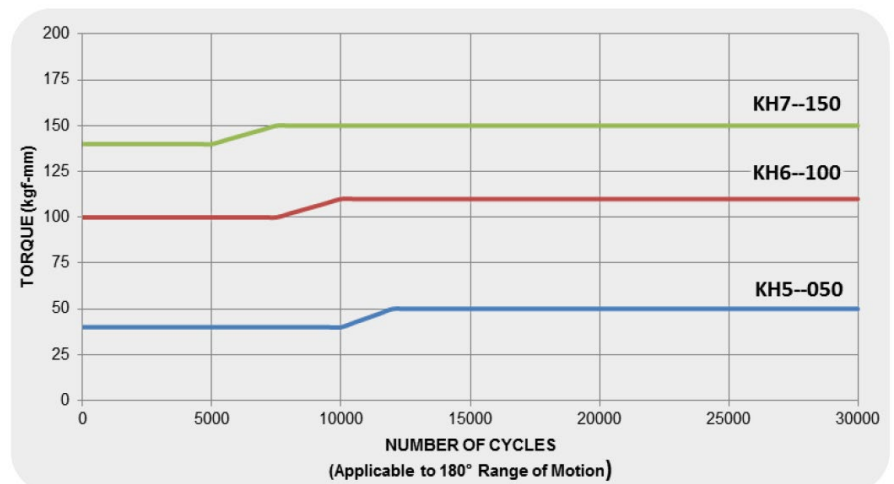
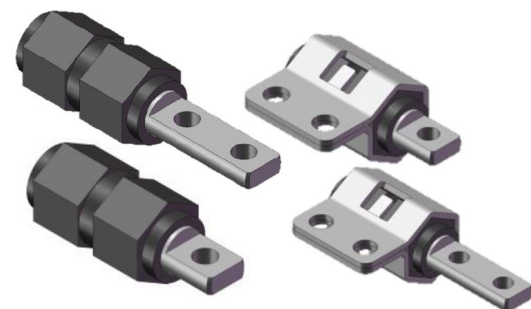



A – Without support
(Assembly in HEX housing)



B – With support
(Left or right assembly)

A standard range is available, but custom shaft configurations are available. Contact technical support for more information. Example of a standard Hexatorq part code:

K H 5 2 B 050 R

Type	Ø Shaft	N. of shaft holes	Support	Torque value (Kgf-mm)	Assembly
KH KATO Hinge	5.0 6.0 7.0	1 2	A – Without support B – With support	25	(Only for B models with support) L – Left R – Right
				50	
				75	
				100	
				125	
150					

Calculating the torque requirements

Use the following formula: $T = W \times L \times \text{Cos}(A)$

Where:

- A – Angle
- L – Distance from the Center of Gravity
- T – Torque
- W – Weight of the object to be supported

Example:

W = 2 lbs – L= 4” inch – Angle = 0°

$T = (2) (4) \text{Cos}(0^\circ)$

$T = 8\text{ lbf} - \text{in.}$

Example:

W = 0.9Kg L= 101.6mm Angle = 0°

$T = (2) (4) \text{Cos}(0^\circ)$

$T = 92.16 \text{ kgf-mm}$

Notes:

1. To convert from lbf-in to kgf-mm, multiply by 11.5212
2. To convert from kgf-mm to lbf-in, multiply by 0.0868
3. If 2 hinges are used: $8 \text{ lb-in} / 2 = 4 \text{ lb-in per hinge}$ – $92.16 \text{ kgf-mm} / 2 = 46,08 \text{ kgf-mm per hinge}$

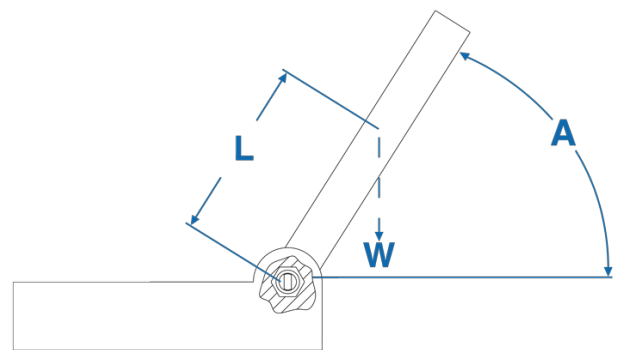

Model A Without support

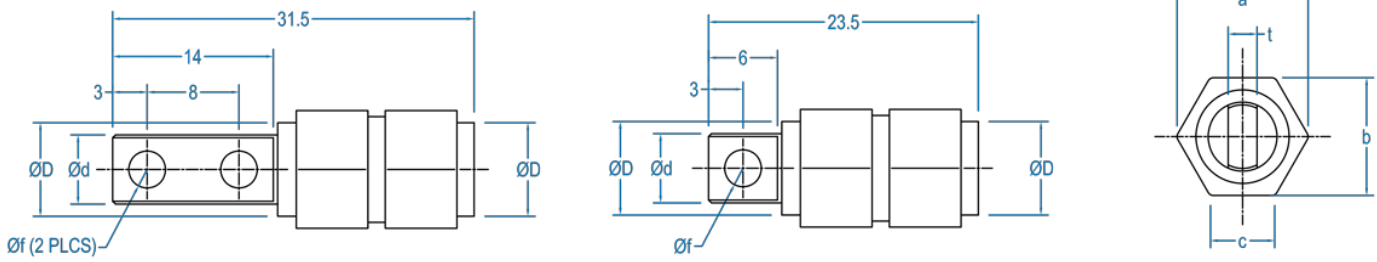

Code	Torque		Model A Without support			Diameters			
	Kgf-mm	lbf-in	A	b	c	D	d	f	t
KH51A025 KH52A025	25	2.2	9.3	8.2	4.8	7.0	5.0	2.7	2.0
KH51A050 KH52A050	50	4.3	9.3	8.2	4.8	7.0	5.0	2.7	2.0
KH61A075 KH62A075	75	6.5	11.6	10.2	5.8	8.1	6.0	3.2	2.5
KH71A100 KH72A100	100	8.7	11.6	10.2	5.8	8.1	6.0	3.2	2.5
KH71A125 KH72A125	125	10.9	14.0	12.2	7.0	10.2	7.0	3.2	3.0
KH71A150 KH72A150	150	13.0	14.0	12.2	7.0	10.2	7.0	3.2	3.0

Model B with support

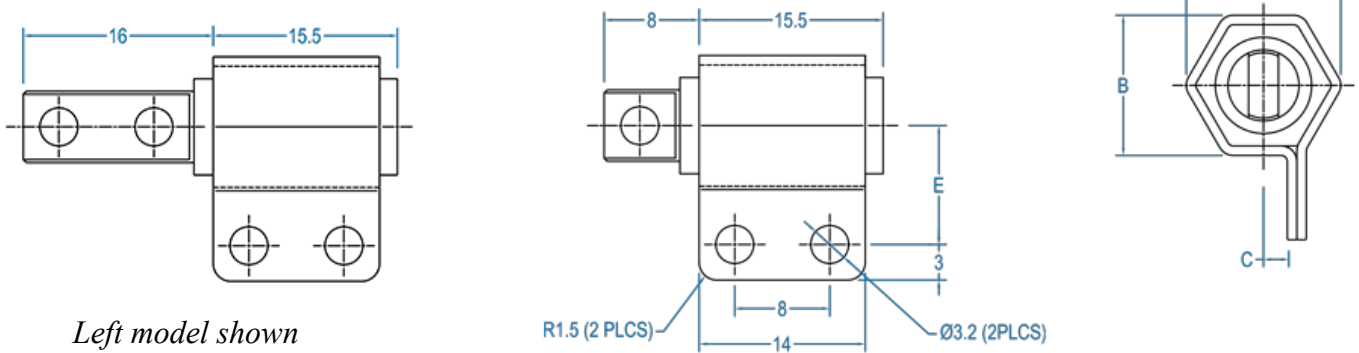

Left model shown

Code	Torque		Model B with support				Diameters			
	Kgf-mm	lbf-in	A (Ref)	B	C	E	D	d	f	t
KH51B025 KH52B025	25	2.2	9.3	8.2	4.8	9	7.0	5.0	2.7	2.0
KH51B050 KH52B050	50	4.3	9.3	8.2	4.8	9	7.0	5.0	2.7	2.0
KH61B075 KH62B075	75	6.5	11.6	10.2	5.8	10	8.1	6.0	3.2	2.5
KH71B100 KH72B100	100	8.7	11.6	10.2	5.8	10	8.1	6.0	3.2	2.5
KH71B125 KH72B125	125	10.9	14.0	12.2	7.0	11	10.2	7.0	3.2	3.0
KH71B150 KH72B150	150	13.0	14.0	12.2	7.0	11	10.2	7.0	3.2	3.0



Model A – 1 hole



KH71A150



KH51A025



Model A – 2 holes



KH72A125



KH52A050



Model B – 1 holes – right assembly



KH71B125L



KH61B100R



Model B – 1 hole – left assembly



KH72B150L



KH52B025R

SureTorq series hinges

The KATO Suretorq hinges have been developed to provide lightweight solutions for devices requiring position control, and they are manufactured with a high-quality stainless steel body. Maintaining a specific angle within design parameters, the Suretorque hinge range exhibits a very low percentage of torque drop compared to initial values, even when used in both directions. At 50,000 cycles, Suretorq hinges show less than a 10% performance drop.

Suretorq hinges are available in standard sizes to meet the requirements of common applications. Design, durability, and product validation tests have been conducted. By using KATO Suretorq hinges, it is possible to significantly reduce design and production timelines.

Suretorq hinges are suitable for a wide range of applications, including Notebook PCs, digital cameras, medical devices, and dental equipment.

Features and Benefits

- Constant torque - Designed for 50,000 cycles or more without failures!
- High-strength hinges - Virtually no wear.
- Lightweight, compact, maximizing space and weight savings.
- ST060 & ST080 allow bi-directional mounting.
- Small diameter for the thinner products.
- Available with both Symmetric and Asymmetric torque.

SureTorq Application example

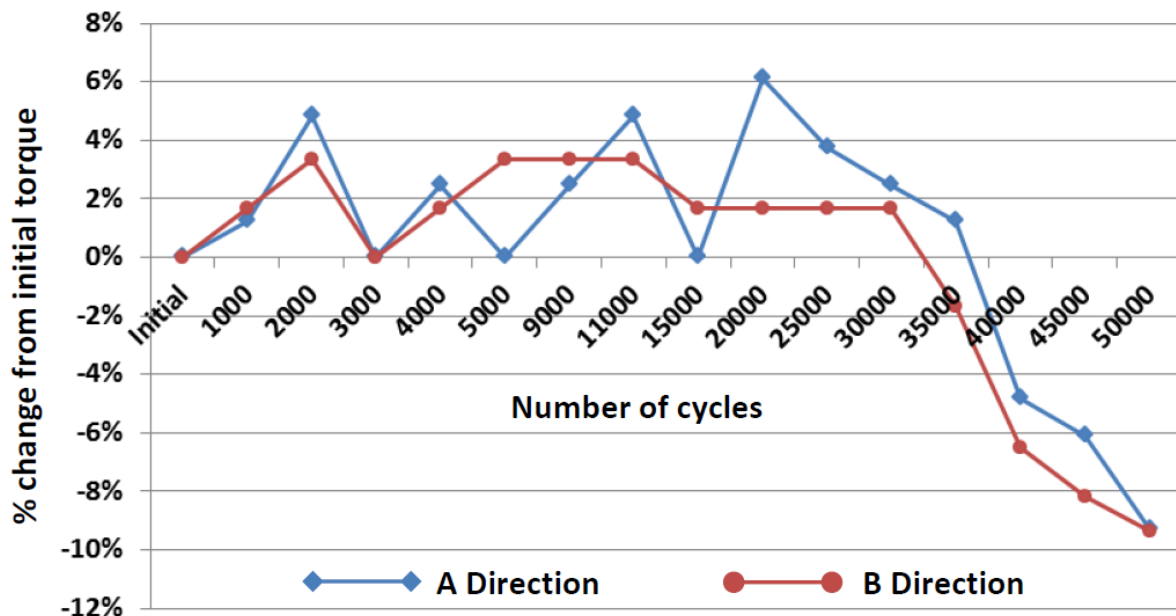
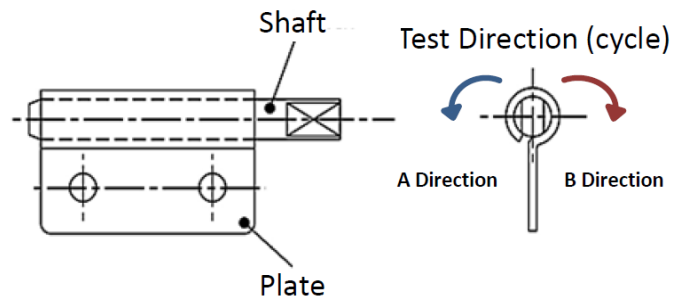
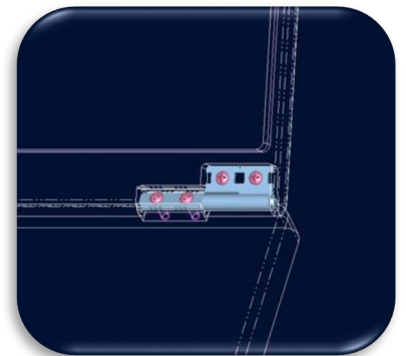



ST010 – ST040
(Left or right assembly)



ST060 – ST080
(Left, right, or bi-directional assembly)

A standard range is available, but custom shaft configurations are available. Contact technical support for more information. Example of a standard SureTorq part code:

S T 060 B 0

Type	Torque value (Kgf-mm)	Style	Assembly
ST SureTorq	10	A – Left OR right assembly B – Bi-Directional	0 - Left 1 - Right
	15		
	25		
	30		
	40		
	60		
	80		

Calculating the torque requirements

Use the following formula: $T = W \times L \times \cos(A)$

Where:

- A – Angle
- L – Distance from the Center of Gravity
- T – Torque
- W – Weight of the object to be supported

Example:

W = 2 lbs – L= 4" inch – Angle = 0°

$T = (2) (4) \cos(0^\circ)$

$T = 8\text{ lbf} - \text{in.}$

Example:

W = 0.9Kg L= 101.6mm Angle = 0°

$T = (2) (4) \cos(0^\circ)$

$T = 92.16 \text{ kgf-mm}$

Notes:

1. To convert from lbf-in to kgf-mm, multiply by 11.5212
2. To convert from kgf-mm to lbf-in, multiply by 0.0868
3. If 2 hinges are used: $8 \text{ lb-in} / 2 = 4 \text{ lb-in}$ per hinge – $92.16 \text{ kgf-mm} / 2 = 46,08 \text{ kgf-mm}$ per hinge

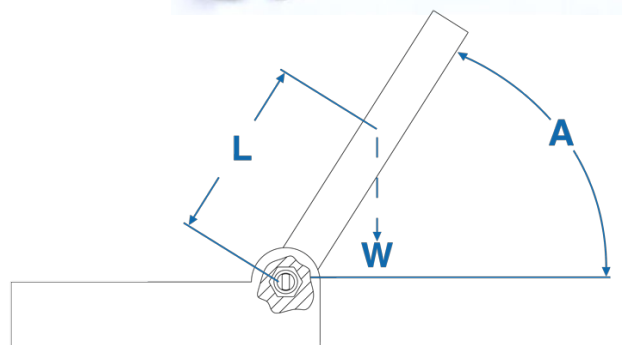
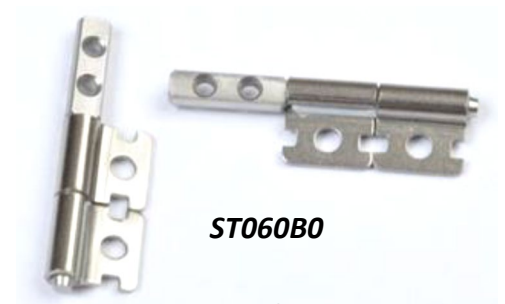

ST010A0 (Right assembly)

ST010A1 (Left assembly)

Torque: 10 kgf-mm | 0.87 lbf-in

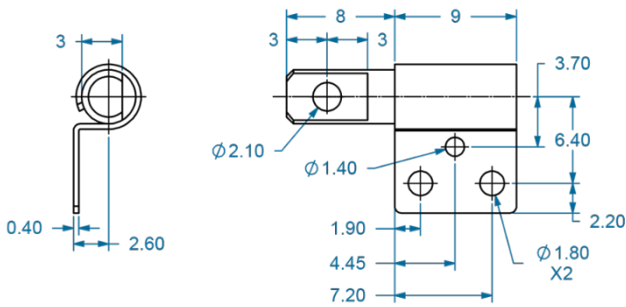

ST015A0 (Right assembly)

ST015A1 (Left assembly)

Torque: 15 kgf-mm | 1.30 lbf-in

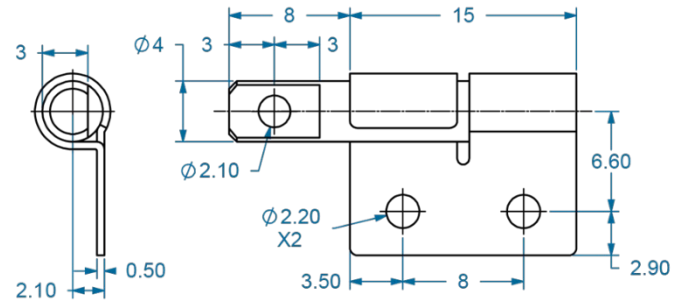

ST025A0 (Right assembly)

ST025A1 (Left assembly)

Torque: 25 kgf-mm | 2.17 lbf-in

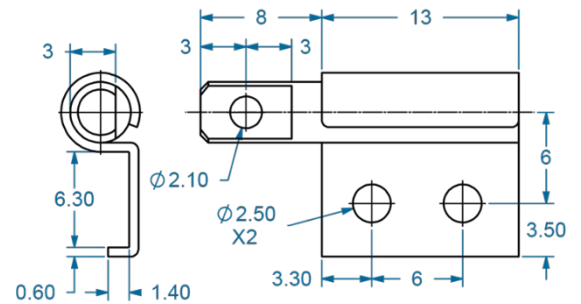

ST030 Torque: 30 kgf-mm | 2.60 lbf-in

ST040 Torque: 40 kgf-mm | 3.47 lbf-in

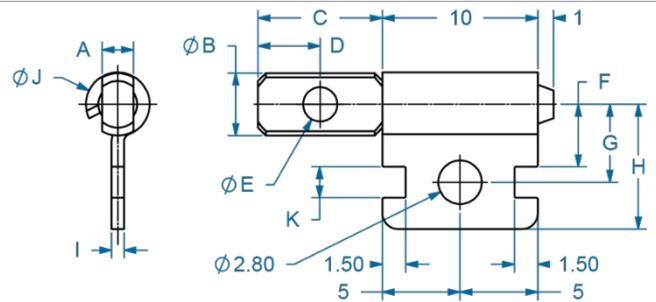

Code	Shaft					Support						Assembly direction
	A	B	C	D	E	F	G	H	I	J	K	
ST030A0 STS030A1	2	4	8	4	2.2	4	5	8	0.8	4.1	2	Left Right
ST040A0 ST040A1	3	4	10	5	2.8	5	6.5	10	1	5	3	Left Right

ST060 Torque: 60 kgf-mm | 5.21 lbf-in

ST080 Torque: 80 kgf-mm | 6.94 lbf-in

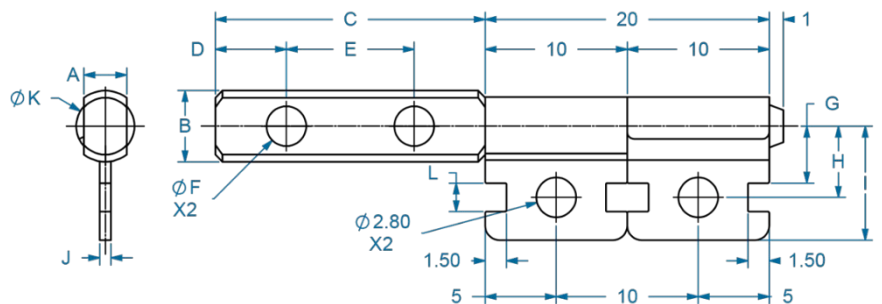

Code	Shaft						Support						Assembly direction
	A	B	C	D	E	F	G	H	I	J	K	L	
ST060A0 ST060A1 ST060B0	2.5	4	13	4	5	2.2	4	5	8	0.8	4.1	2	Left Right Bi-Directional
ST080A0 ST080A1 ST080B0	3	5	19	5	9	2.8	5	6.5	10	1	5	3	Left Right Bi-Directional



Series from ST010 to ST040



ST040A0 - ST040A1



ST010A0 - ST010A1



Series from ST060 to ST080



ST060A0



ST080B0

GO TANGLESS



ΑΔΥΛΠΕΧ