

Revision	Revised By	Description	Date	Approval
New	GP	Initial Release	11-12-18	MO

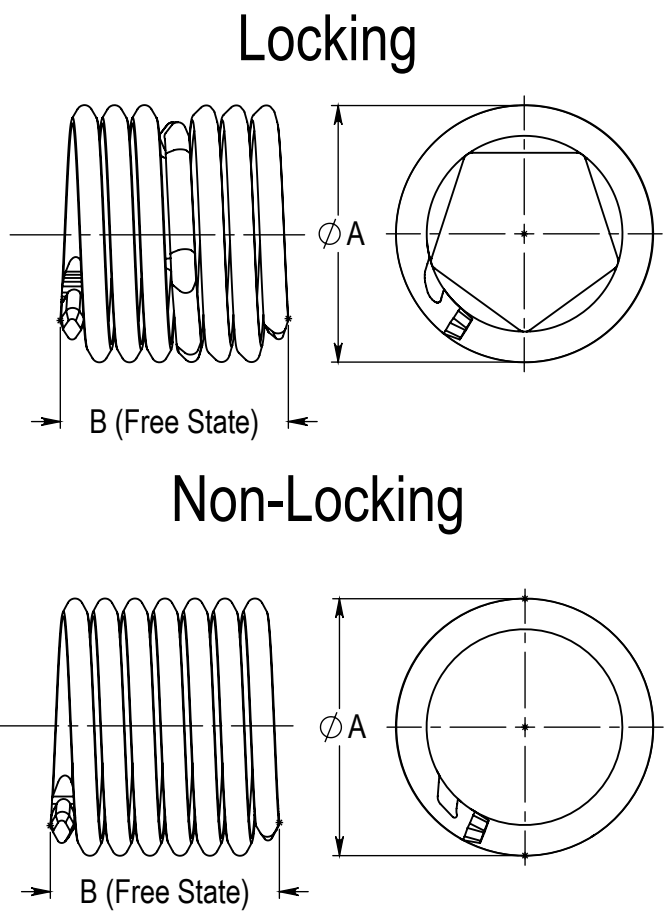

2TLC	-	3	C	-	0285	W	SF
1		2	3		4	5	see note 9

Nominal Thread Size	1		2	3	4					5	Free Outer Diameter (A)		Number of Coils (B, see note 4)				
	Insert Style				Size	Material	Nominal Length					Finish	Min	Max	1D	1.5D	2D
	Locking	Non-Locking	1D	1.5D			2D	2.5D	3D								
1-64	2TLC	2TNC	01	B- Phosphor Bronze C- CRES Steel (304 Stainless Steel) ¹⁰ N- Nitronic 60® M- Nimonic 90® T- Inconel X-750	0.073	0.110	0.146	0.182	0.215	Blank- No Finish W- Dry Film Lubricant Y- Cadmium V- Silver Plating A- Passivation P- Xylan B- Blue Dye G- Green Dye	0.095	0.103	2-3/4	4-7/8	6-7/8	8-7/8	10-7/8
2-56			02		0.086	0.129	0.172	0.215	0.258		0.110	0.119	3	5-1/4	7-3/8	9-5/8	11-7/8
4-40			04		0.112	0.168	0.224	0.280	0.336		0.144	0.159	2-3/4	4-3/4	6-3/4	8-7/8	10-7/8
6-32			06		0.138	0.207	0.276	0.345	0.414		0.178	0.193	2-3/4	4-3/4	6-7/8	8-7/8	10-7/8
8-32			2		0.164	0.246	0.328	0.410	0.492		0.205	0.220	3-1/2	6	8-3/8	10-3/4	13-1/4
10-24			3		0.190	0.285	0.380	0.475	0.570		0.244	0.259	2-7/8	5	7-1/8	9-1/4	11-3/8
1/4-20			4		0.250	0.375	0.500	0.625	0.750		0.310	0.330	3-3/8	5-3/4	8	10-3/8	12-3/4
5/16-18			5		0.312	0.469	0.625	0.781	0.938		0.380	0.400	4	6-5/8	9-1/4	11-7/8	14-5/8
3/8-16			6		0.375	0.562	0.750	0.938	1.125		0.452	0.472	4-3/8	7-1/4	10	12-7/8	15-3/4

- Notes:
- For each threadsize, complete part number consists of combining columns 1-5 across each row.
 - The nominal length is a calculated number and cannot be used to measure the insert in the free state. It is the actual installed length of the insert plus 0.5 pitch ($L_n = L_a + 0.5P$), see column 4.
 - The nominal length of the insert is a function of the nominal thread size ($1.5D \times 0.190 \text{ in} = 0.285 \text{ in}$).
 - The number of free coils is measured from notch to notch. It is the total number of revolutions ± 0.25 coil.
 - Assembled length of insert is in accordance to NASM33537.
 - Locking torque specification conforms to NASM8846.
 - Inserts meet NAS1130 specification.
 - When assembled in an STI thread, conforming to NASM33537 specification, the finished thread shall conform to FED-STD-H28/2 and shall accept external threads per MIL-S-7742 or AS8879 specification.
 - For strip-feed packaged inserts, use "SF" at the end of the part number. Not available for all sizes and all plating options. Leave blank for bulk packaged inserts.
 - 304 Stainless steel is the most popular wire material and meets AS7245 specification.

KATO Fastening Systems, Inc., 11864 Fishing Point Dr., Newport News, VA 23606, www.katofastening.com			
Drawing No.	KSTD-007	Description	KATO Tangless UNC Standard, Locking & Non-Locking Screw Thread Inserts (STI)
Revision	New	Drawn By	G. Patterson
Date	11-12-18	Approved By	M. Oana



THIS DRAWING CONTAINS PROPRIETARY INFORMATION AND IS COVERED BY U.S. & INTERNATIONAL PATENTS. REPRODUCTION IN WHOLE, OR IN PART, WITHOUT THE EXPRESS WRITTEN CONSENT OF KATO FASTENING SYSTEMS, INC. IS STRICTLY PROHIBITED