

INSERT REMOVAL

If necessary, KATO Tangless inserts can be easily removed without damaging the workpiece, or the insert, by using the corresponding KATO Tangless Removal Tool (2KRT Series). The removal tool can also be used to back up inserts that are installed too deep.

TOOL MAINTENANCE

Installation tools should be periodically inspected for damage or wear. Tools should be kept clean so that foreign objects and debris (chips, oils, and dirt) will not clog the tool and prevent the Pawl from fully pivoting inside the Mandrel. Operator misuse can contribute to premature wear and/or damage to the Pawl or Mandrel.

PARTS REPLACEMENT

Replacement Pawls, Pawl Kits (includes 1 Pawl, 2 Pins, and 2 Springs), and replacement Mandrels are available from KATO (see Parts List below).

FOLLOW THE PROCEDURES BELOW TO REPLACE A DAMAGED PAWL OR MANDREL.

1. Loosen the Lock Nut.
2. Remove the Lock Nut and Adjusting Sleeve from the Mandrel.
3. Push out the Pin (see figure 1). Be careful not to lose the Pin.
4. Remove the Pawl from the Mandrel slot.
5. Remove the Spring from the Mandrel. Be careful not to lose the Spring.

TO REASSEMBLE:

6. Insert the Spring into the Mandrel. (The Spring goes into the hole closest to the Pin)
7. Insert the Pawl into the Mandrel Slot.
8. Line up the Pin holes (Pawl & Mandrel) and press in the Pin.
9. Check for spring action and free movement of the Pawl in the Mandrel slot.
10. Thread the Lock Nut and Adjusting Sleeve back into the Mandrel.

SAFETY

Always wear eye protection when working with KATO tools.



Via degli Andreani, 9
40037 Sasso Marconi (BO) ITALY
Tel +39 051 735744
info@tecnimetal-tm.com
www.tecnimetal-tm.com
www.tecnimetal-tm.eu

PARTS LIST

REPLACEMENT PARTS	KATO PART NUMBER
Pawl	2KIPX-XX
Pawl Kit (includes 1 pawl, 2 pins and 2 springs)	2KIPX-XXK
Replacement Mandrel	2KHEX-XXM
Adjusting Sleeve (Nylon Guard not included)	2KHEX-XXH
Nylon Guard	2KHEX-XXG

X-XX Signifies Thread Type & Size Designation. For example, 2KHEC-02M



INSTRUCTIONS FOR USING KATO TANGLESS® COILTHREAD® INSERT TOOLS

THE FOLLOWING INSTRUCTIONS ARE APPLICABLE TO THE
KATO TANGLESS HEX ELECTRIC INSTALLATION TOOL (2KHE Series)

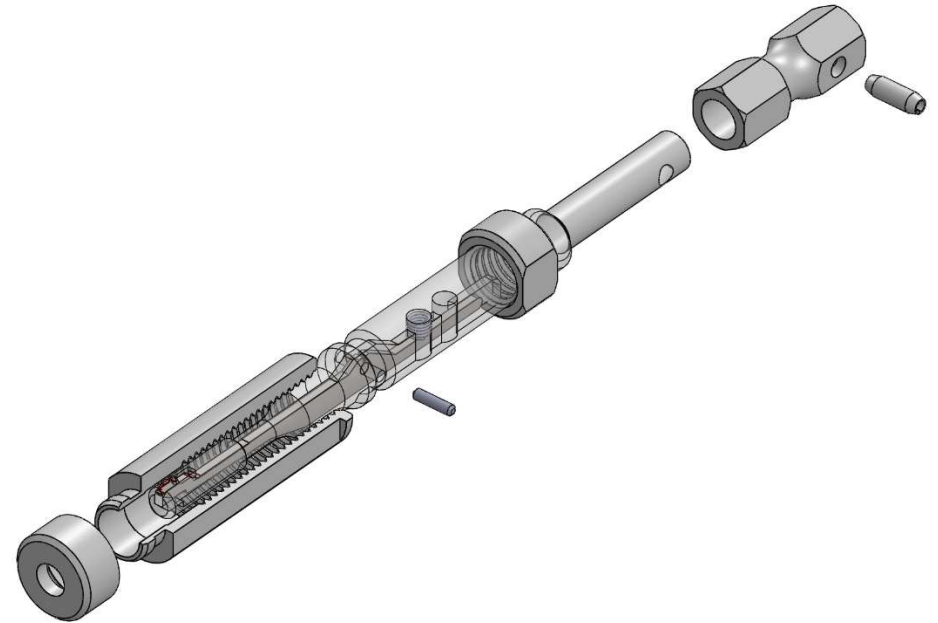

BEFORE YOU BEGIN PLEASE REVIEW

- Proper hole preparation procedures.
- The KFS-20 (CT5420) instructions prior to use.
- The KATO Linear Arm (2KLRM-1) to reduce operator fatigue and injury.

IMPORTANT NOTES

- A step by step instructional video can be found in the KATOpedia section of the KATO website www.katofastening.com.
- The Installation Mandrel (see figure 1) is designed to be used with the new KFS-20 (CT5420), and the previous model KFS-12 (CT5408) Electric Driver, sizes 2-56 to 3/8" & M2.5 to M12.
- Low torque range spring (light blue) is for installing insert sizes 2-56 to 6-32, and M2.5 to M4.
- High torque range spring (light silver) is for installing insert sizes 6-32 to 3/8", and M4 thru M12.

REQUIRED COMPONENTS

The KATO Tangless Hex Electric Installation System requires:

- CT5420: KFS-20 Brushless Electric Driver & T-45BL Power Transformer
- 2KHE Series: KATO Tangless Hex Electric Tool (one for each thread size)
- 2KLRM-1: KATO Linear Torque Arm (recommended)

COMPONENTS LIST

2KHE Series Installation Mandrel Assembly (includes the following parts):

- 1 Hex Mandrel Assembly (1 Hex Mandrel, 1 Pawl, 1 Spring, 1 Pin)
- 1 Adjusting Sleeve
- 1 Nylon Guard
- 1 Lock Nut
- 2 Wrenches (select sizes only)

DEPTH ADJUSTMENT AND TOOL ASSEMBLY

1. Use the included wrenches (provided with the 2KHE series, UNC and UNF sizes only) to loosen the Lock Nut and Adjusting Sleeve on the Mandrel.
2. Thread the Lock Nut and Adjusting Sleeve towards the back of the Mandrel to fully expose the front threads.
3. Thread the insert to be installed onto the Mandrel until the Pawl engages the drive notch. Tangless inserts are Bi-Directional, so there is no need to orient the insert.
4. Turn the Adjusting Sleeve until the Nylon Guard is approximately 1 thread behind the end of the insert. This will ensure proper installation depth (3/4 – 1 1/2 threads below the surface for a hole with a countersink; 1/4 - 1/2 threads below the surface for a hole without a countersink).
Note: Inserts may vary ± 0.25 coil. KATO recommends that the installation depth of each lot be tested using a sample tapped hole prior to installing the inserts into the production part.
5. Use the two wrenches to lightly tighten the Lock Nut against the Adjusting Sleeve. (Be careful not to move the Adjusting Sleeve when tightening)
6. To use the quick-disconnect feature of the KFS-20 Brushless Electric Driver (CT5420) pull the sleeve back while you insert the Mandrel into the hex shaft. Then, release the sleeve to lock the Mandrel in place.

TORQUE ADJUSTMENT & INSERT INSTALLATION

BULK INSERTS:

7. Always use the minimum amount of torque that will install the insert. Start with a very low torque setting on the electric driver. To adjust the torque, pull back on the Torque Adjustment Knob, tightening it to increase torque (clockwise direction) and loosening it to decrease torque (counterclockwise direction). The Torque Adjustment Knob will lock into place every 180°.
8. Hold the electric tool perpendicular to the tapped hole and align the insert. Straight alignment will provide smooth installation and longer tool life.
9. Actuate the driver by pressing the Trigger.
10. Continue to hold down the Trigger as the Installation Mandrel threads the insert into the tapped hole.

11. Once the insert is fully installed, the Electric tool will automatically reverse. Be sure to hold the Trigger down until the Mandrel fully retracts from the installed insert. If the Trigger is released prematurely, the Electric Driver will reset. When the Trigger is depressed again the Driver will run forward. Hold the Trigger until the Mandrel exits the tapped hole.

Note: The insert can be loaded onto the mandrel manually, or you can hold the insert in one hand and tap the Trigger on the Electric Driver with the other hand.

STRIP-FEED INSERTS:

KATO does not recommend using strip-feed inserts with non-rewinder electric tools. The KATO 2KPE Series Electric Tool Front End Assembly is strongly recommended when using strip-feed inserts.

DO NOT APPLY ANY DOWNWARD FORCE OR TRY TO FORCE THE INSERT INTO THE HOLE, LET THE WEIGHT OF THE TOOL DO THE WORK. FORCING THE INSERT INTO THE TAPPED HOLE MAY RESULT IN INSTALLATION FAILURE AND CAUSE DAMAGE TO THE TOOL AND/OR WORKPIECE.

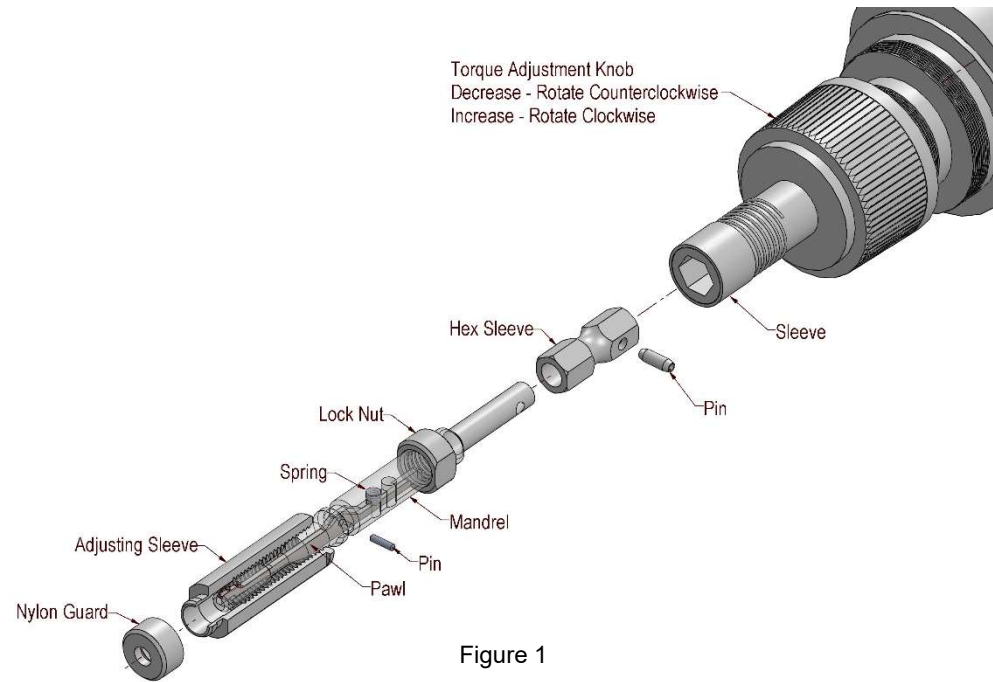

TIPS & TRICKS

Having difficulty getting the insert started? Try one or more of these helpful tips:

- Tap the Trigger on the Electric Driver in short intervals until the insert begins to enter the tapped hole.
- Dipping the insert in Alcohol or another non-residual solution will provide lubrication and help facilitate installation. **USING ALCOHOL ON LOCKING INSERTS WILL CAUSE THE RED DYE TO BLEED.**
- Back off the insert approximately one turn so that the notch disengages from the Pawl, and attempt installation from this position.